

***Service Manual***  
**Agilent Model 66332A**  
**Dynamic Measurement DC Source**  
**and Agilent Model 6632B, 6633B, 6634B**  
**System DC Power Supply**

For instruments with Serial Numbers:

Agilent 66332A: US37470791 and up

Agilent 6632B: US37471966 and up

Agilent 6633B: US37470746 and up

Agilent 6634B: US37470655 and up

For instruments with higher serial numbers, a change page may be included.

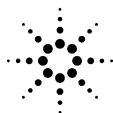

**Agilent Technologies**

---

# Warranty Information

## CERTIFICATION

*Agilent Technologies certifies that this product met its published specifications at time of shipment from the factory. Agilent Technologies further certifies that its calibration measurements are traceable to the United States National Bureau of Standards, to the extent allowed by the Bureau's calibration facility, and to the calibration facilities of other International Standards Organization members.*

## WARRANTY

This Agilent Technologies hardware product is warranted against defects in material and workmanship for a period of three years from date of delivery. Agilent Technologies software and firmware products, which are designated by Agilent Technologies for use with a hardware product and when properly installed on that hardware product, are warranted not to fail to execute their programming instructions due to defects in material and workmanship for a period of 90 days from date of delivery. During the warranty period Agilent Technologies will, at its option, either repair or replace products which prove to be defective. Agilent Technologies does not warrant that the operation for the software firmware, or hardware shall be uninterrupted or error free.

For warranty service, with the exception of warranty options, this product must be returned to a service facility designated by Agilent Technologies. Customer shall prepay shipping charges by (and shall pay all duty and taxes) for products returned to Agilent Technologies. for warranty service. Except for products returned to Customer from another country, Agilent Technologies shall pay for return of products to Customer.

Warranty services outside the country of initial purchase are included in Agilent Technologies' product price, only if Customer pays Agilent Technologies international prices (defined as destination local currency price, or U.S. or Geneva Export price).

If Agilent Technologies is unable, within a reasonable time to repair or replace any product to condition as warranted, the Customer shall be entitled to a refund of the purchase price upon return of the product to Agilent Technologies.

## LIMITATION OF WARRANTY

The foregoing warranty shall not apply to defects resulting from improper or inadequate maintenance by the Customer, Customer-supplied software or interfacing, unauthorized modification or misuse, operation outside of the environmental specifications for the product, or improper site preparation and maintenance. NO OTHER WARRANTY IS EXPRESSED OR IMPLIED. AGILENT TECHNOLOGIES. SPECIFICALLY DISCLAIMS THE IMPLIED WARRANTIES OF MERCHANTABILITY AND FITNESS FOR A PARTICULAR PURPOSE.

## EXCLUSIVE REMEDIES

THE REMEDIES PROVIDED HEREIN ARE THE CUSTOMER'S SOLE AND EXCLUSIVE REMEDIES. AGILENT TECHNOLOGIES SHALL NOT BE LIABLE FOR ANY DIRECT, INDIRECT, SPECIAL, INCIDENTAL, OR CONSEQUENTIAL DAMAGES, WHETHER BASED ON CONTRACT, TORT, OR ANY OTHER LEGAL THEORY.

## ASSISTANCE

The above statements apply only to the standard product warranty. Warranty options, extended support contacts, product maintenance agreements and customer assistance agreements are also available. Contact your nearest Agilent Technologies Sales and Service office for further information on Agilent Technologies' full line of Support Programs.

---

# Safety Summary

*The following general safety precautions must be observed during all phases of operation of this instrument. Failure to comply with these precautions or with specific warnings elsewhere in this manual violates safety standards of design, manufacture, and intended use of the instrument. Agilent Technologies assumes no liability for the customer's failure to comply with these requirements.*

## **WARNING**

Servicing instructions are for use by service-trained personnel. To avoid dangerous electrical shock, do not perform any servicing unless you are qualified to do so. Some procedures described in this manual are performed with power supplied to the instrument while its protective covers are removed. If contacted, the energy available at many points may result in personal injury.

## **BEFORE APPLYING POWER.**

Verify that the product is set to match the available line voltage, the correct line fuse is installed, and all safety precautions (see following warnings) are taken. In addition, note the instrument's external markings described under "Safety Symbols"

## **GROUND THE INSTRUMENT.**

Before switching on the instrument, the protective earth terminal of the instrument must be connected to the protective conductor of the (mains) power cord. The mains plug shall be inserted only in an outlet socket that is provided with a protective earth contact. This protective action must not be negated by the use of an extension cord (power cable) that is without a protective conductor (grounding). Any interruption of the protective (grounding) conductor or disconnection of the protective earth terminal will cause a potential shock hazard that could result in personal injury.

## **FUSES**

Only fuses with the required rated current, voltage, and specified type (normal blow, time delay, etc.) should be used. Do not use repaired fuses or short-circuited fuseholders. To do so could cause a shock or fire hazard.

## **KEEP AWAY FROM LIVE CIRCUITS.**

Operating personnel must not remove instrument covers. Component replacement and internal adjustments must be made by qualified service personnel. Do not replace components with power cable connected. Under certain conditions, dangerous voltages may exist even with the power cable removed. To avoid injuries, always disconnect power, discharge circuits and remove external voltage sources before touching components.

## **DO NOT SERVICE OR ADJUST ALONE.**

Do not attempt internal service or adjustment unless another person, capable of rendering first aid and resuscitation, is present. Any adjustment, maintenance, and repair of this instrument while it is opened and under voltage should be avoided as much as possible. When this is unavoidable, such adjustment, maintenance, and repair should be carried out only by a skilled person who is aware of the hazard involved.

## **DO NOT SUBSTITUTE PARTS OR MODIFY INSTRUMENT.**



















Because of the danger of introducing additional hazards, do not install substitute parts or perform any unauthorized modification to the instrument. Return the instrument to an Agilent Technologies Sales and Service Office for service and repair to ensure that safety features are maintained.

## **SAFETY SYMBOLS**

Refer to the table on the following page

**WARNING** The WARNING sign denotes a hazard. It calls attention to a procedure, practice, or the like, which, if not correctly performed or adhered to, could result in personal injury. Do not proceed beyond a WARNING sign until the indicated conditions are fully understood and met.

**Caution** The CAUTION sign denotes a hazard. It calls attention to an operating procedure, or the like, which, if not correctly performed or adhered to, could result in damage to or destruction of part or all of the product. Do not proceed beyond a CAUTION sign until the indicated conditions are fully understood and met.

<b>Safety Symbol Definitions</b>	
<b>Symbol</b>	<b>Description</b>
	Direct current
	Alternating current
	Both direct and alternating current
	Three-phase alternating current
	Earth (ground) terminal
	Protective earth (ground) terminal
	Frame or chassis terminal
	Terminal is at earth potential (Used for measurement and control circuits designed to be operated with one terminal at earth potential.)
	Terminal for Neutral conductor on permanently installed equipment
	Terminal for Line conductor on permanently installed equipment
	On (supply)
	Off (supply)
	Standby (supply) Units with this symbol are not completely disconnected from ac mains when this switch is off. To completely disconnect the unit from ac mains, either disconnect the power cord or have a qualified electrician install an external switch.
	In position of a bi-stable push control
	Out position of a bi-stable push control
	Caution, risk of electric shock
	Caution, hot surface
	Caution (refer to accompanying documents)

---

## Notice

The information contained in this document is subject to change without notice. Agilent Technologies makes no warranty of any kind with regard to this material, including but not limited to, the implied warranties of merchantability, and fitness for a particular purpose.

**Agilent Technologies shall not be liable for errors contained herein or for incidental or consequential damages in connection with the furnishing, performance or use of this material.**

This document contains proprietary information which is protected by copyright. All rights are reserved. No part of this document may be photocopied, reproduced, or translated into another language without the prior written consent of Agilent Technologies, Inc.

© Copyright 1997, 2000 Agilent Technologies, Inc.

---

## Printing History

The edition and current revision of this manual are indicated below. Reprints of this manual containing minor corrections and updates may have the same printing date. Revised editions are identified by a new printing date. A revised edition incorporates all new or corrected material since the previous printing date.

Changes to the manual occurring between revisions are covered by change sheets shipped with the manual. In some cases, the manual change applies only to specific instruments. Instructions provided on the change sheet will indicate if a particular change applies only to certain instruments.

Edition 1.....June, 1997

Edition 2.....September, 2000

---

## Instrument Identification

The power supply is identified by a unique serial number such as US36310101. The items in this serial number are explained as follows:

**US36310101**      The first two letters indicate the country of manufacture. US = United States.

The next four digits are the year and week of manufacture or last significant design change. Add 1960 to the first two digits to determine the year. For example, 36=1996. The third and fourth digits specify the week of the year (31 = the thirty-first week).

The last four digits (0101) are a unique number assigned to each unit.

---

# Table of Contents

<b>Warranty Information</b>	<b>2</b>
<b>Safety Summary</b>	<b>3</b>
<b>Notice</b>	<b>4</b>
<b>Printing History</b>	<b>5</b>
<b>Instrument Identification</b>	<b>5</b>
<b>Table of Contents</b>	<b>6</b>
<b>INTRODUCTION</b>	<b>9</b>
<b>Organization</b>	<b>9</b>
<b>Safety Considerations</b>	<b>9</b>
<b>Related Documents</b>	<b>9</b>
<b>Revisions</b>	<b>10</b>
Manual Revisions	10
Firmware Revisions	10
<b>Electrostatic Discharge</b>	<b>10</b>
<b>VERIFICATION AND PERFORMANCE TESTS</b>	<b>11</b>
<b>Introduction</b>	<b>11</b>
<b>Test Equipment Required</b>	<b>11</b>
<b>Measurement Techniques</b>	<b>12</b>
Setup for Most Tests	12
Electronic Load	13
Current-Monitoring Resistor	13
<b>Operation Verification Tests</b>	<b>13</b>
<b>Performance Tests</b>	<b>13</b>
Programming	13
<b>Constant Voltage (CV) Tests</b>	<b>14</b>
CV Setup	14
Voltage Programming and Readback Accuracy	14
CV Load Effect	14
CV Source Effect	15
CV Noise (PARD)	15
Transient Recovery Time	16
<b>Constant Current (CC) Tests</b>	<b>16</b>
CC Setup	16
Current Programming and Readback Accuracy	16
Current Sink (CC-) Operation	17
CC Load and Line Regulation	17
CC Load Effect	18
CC Source Effect	18
CC Noise (PARD)	19
<b>Performance Test Equipment Form</b>	<b>19</b>
<b>Performance Test Record Form</b>	<b>20</b>
<b>TROUBLESHOOTING</b>	<b>23</b>
<b>Introduction</b>	<b>23</b>
<b>Test Equipment Required</b>	<b>24</b>
<b>Overall Troubleshooting</b>	<b>24</b>
Flow Charts	24
<b>Specific Troubleshooting Procedures</b>	<b>34</b>

Power-on Self-test Failures	37
CV/CC Status Annunciators Troubleshooting	38
Bias and Reference Supplies	38
J307 Voltage Measurements	39
Manual Fan Speed Control	40
Disabling Protection Features	40
<b>Post-repair Calibration</b>	<b>41</b>
Inhibit Calibration Switch	41
Calibration Password	41
<b>Initialization</b>	<b>42</b>
<b>ROM Upgrade</b>	<b>42</b>
Identifying the Firmware	42
Upgrade Procedure	42
<b>Disassembly Procedures</b>	<b>43</b>
List of Required Tools	43
Cover, Removal and Replacement	44
A2 Interface Board, Removal and Replacement	44
Front Panel Assembly, Removal and Replacement	44
A3 Front Panel Board, Removal and Replacement	45
A1 Main Control Board	45
T1 Power Transformer, Removal and Replacement	45
Line Voltage Wiring	46
<b>PRINCIPLES OF OPERATION</b>	<b>47</b>
<b>Introduction</b>	<b>47</b>
<b>I/O Interface Signals</b>	<b>47</b>
<b>A3 Front Panel Circuits</b>	<b>48</b>
<b>A2 Interface Circuits</b>	<b>48</b>
Primary Interface	48
Secondary Interface	48
<b>A1 Main Board Circuits</b>	<b>50</b>
Power Circuits	50
Control Circuits	52
<b>REPLACEABLE PARTS LIST</b>	<b>55</b>
<b>Introduction</b>	<b>55</b>
<b>DIAGRAMS</b>	<b>71</b>
<b>Introduction</b>	<b>71</b>
General Schematic Notes	71
Backdating	71
<b>INDEX</b>	<b>81</b>





# Introduction

---

## Organization

This manual contains information for troubleshooting and repairing to the component level the Agilent Model 66332A Dynamic Measurement DC Source and the Agilent Model 6632B, 6633B, 6634B System DC Power Supplies. Hereafter all models will be referred to as the dc power supply.

This manual is organized as follows:

<b>Chapter 1</b>	Organization
<b>Chapter 2</b>	Performance tests
<b>Chapter 3</b>	Troubleshooting procedures
<b>Chapter 4</b>	Principles of operation on a block-diagram level
<b>Chapter 5</b>	Replaceable parts
<b>Chapter 6</b>	Diagrams

---

## Safety Considerations

---

**WARNING:** Hazardous voltages exist within the dc power supply chassis.

---

This dc power supply; is a Safety Class I instrument, which means it has a protective earth terminal. This terminal must be connected to earth ground through a power source equipped with a 3-wire, ground receptacle. Refer to the "Safety Summary" page at the beginning of this manual for general safety information. Before operation or repair, check the dc power supply and review this manual for safety warnings and instructions. Safety warnings for specific procedures are located at appropriate places in the manual.

---

## Related Documents

The following documents are shipped with your dc power supply:

- a User's Guide, containing installation, operating, and calibration information
- a Programming Guide, containing detailed GPIB programming information.

## Revisions

### Manual Revisions

This manual was written for dc power supplies that have the same manufacturing dates (the first four digits) as those listed on the title page and whose unique identification number (the last four digits) are equal to or higher than those listed in the title page.

---

**NOTE:** If the first four digits of the serial number of your unit are higher than those shown in the title page, your unit was made after the publication of this manual and may have hardware or firmware differences not covered in this manual. If they are significant to the operation and/or servicing of the dc power supply, those differences are documented in one or more Manual Change sheets included with this manual.

---

### Firmware Revisions

You can obtain the firmware revision number by either reading the integrated circuit label, or query the dc power supply using the GPIB \*IDN? query command (See Chapter 3, ROM Upgrade).

---

## Electrostatic Discharge

---

**CAUTION:** The dc power supply has components that can be damaged by ESD (electrostatic discharge). Failure to observe standard antistatic practices can result in serious degradation of performance, even when an actual failure does not occur.

---

When working on the dc power supply, observe all standard, antistatic work practices. These include, but are not limited to:

- Working at a static-free station such as a table covered with static-dissipative laminate or with a conductive table mat (Agilent P/N 9300-0797, or equivalent).
- Using a conductive wrist strap, such as Agilent P/N 9300-0969 or 9300-0970.
- Grounding all metal equipment at the station to a single common ground.
- Connecting low-impedance test equipment to static-sensitive components only when those components have power applied to them.
- Removing power from the dc power supply before removing or installing printed circuit boards.

## Verification and Performance Tests

---

### Introduction

This document contains test procedures to verify that the dc power supply is operating normally and is within published specifications. There are three types of tests as follows:

- Built-in Self Tests**      These tests, run automatically when the power supply is turned on, check most of the digital circuits and the programming and readback DACs.
- Operation Verification**      These tests verify that the power supply is probably operating normally but do not check all of the specified operating parameters.
- Performance Tests**      These tests check that the supply meets all of the operating specifications as listed in the Operating Manual.

---

**NOTE:**      The dc power supply must pass the built-in self-tests before calibration or any of the verification or performance tests can be performed. If the supply fails any of the tests or if abnormal test results are obtained, refer to the troubleshooting procedures in Chapter 3. The troubleshooting procedures will determine if repair and/or calibration is required.

---

### Test Equipment Required

Table 2-1 lists the equipment required to perform the verification and performance tests. A test record sheet with specification limits and measurement uncertainties (when test using the recommended test equipment) may be found at the back of this section.

---

**WARNING:**      **SHOCK HAZARD.** These tests should only be performed by qualified personnel. During the performance of these tests, hazardous voltages may be present at the output of the supply.

---

**Table 2-1. Test Equipment Required for Verification and Performance Tests**

Type	Specifications	Recommended Model
Current Monitor Resistor	15 A (0.1 ohm) 0.04%, for power supplies up to 15 A output	Guildline 9230/15
DC Power Supply	5 V, 10 A	Agilent 6642A, 6653A
Digital Voltmeter	Resolution: 10 nV @ 1V Readout: 8 1/2 digits Accuracy: 20 ppm	Agilent 3458A or equivalent
Electronic Load	20 V, 5 A minimum, with transient capability	Agilent 6060B or equivalent
GPIB Controller	HP Series 300 or other controller with full GPIB capabilities	

## 2 - Verification and Performance Tests

Resistor (substitute for electronic load if load is too noisy for CC PARD test)	1 ohm, 50 W 3 ohm, 100 W (Agilent 66332A/6632B) 24 ohm, 100 W (Agilent 6633B) 99 ohm, 100 W (Agilent 6634B) 1k ohm, 5%, 3W (all models)	Ohmite L50J1R0 Ohmite RLS5R0 (adjustable) Ohmite RLS25R (adjustable) Ohmite RLS100 (adjustable) Agilent 0813-0001
Oscilloscope	Sensitivity: 1 mV Bandwidth Limit: 20 MHz Probe: 1:1 with RF tip	Agilent 54504A or equivalent
RMS Voltmeter	True RMS Bandwidth: 20 MHz Sensitivity: 100 $\mu$ V	Agilent 3400B or equivalent
Variable-Voltage Transformer	Adjustable to highest rated input voltage range. Power: 500 VA	

## Measurement Techniques

### Test Setup

Most tests are performed at the rear terminals of the supply as shown in Figure 2-1a. Measure the dc voltage directly at the +S and -S terminals.

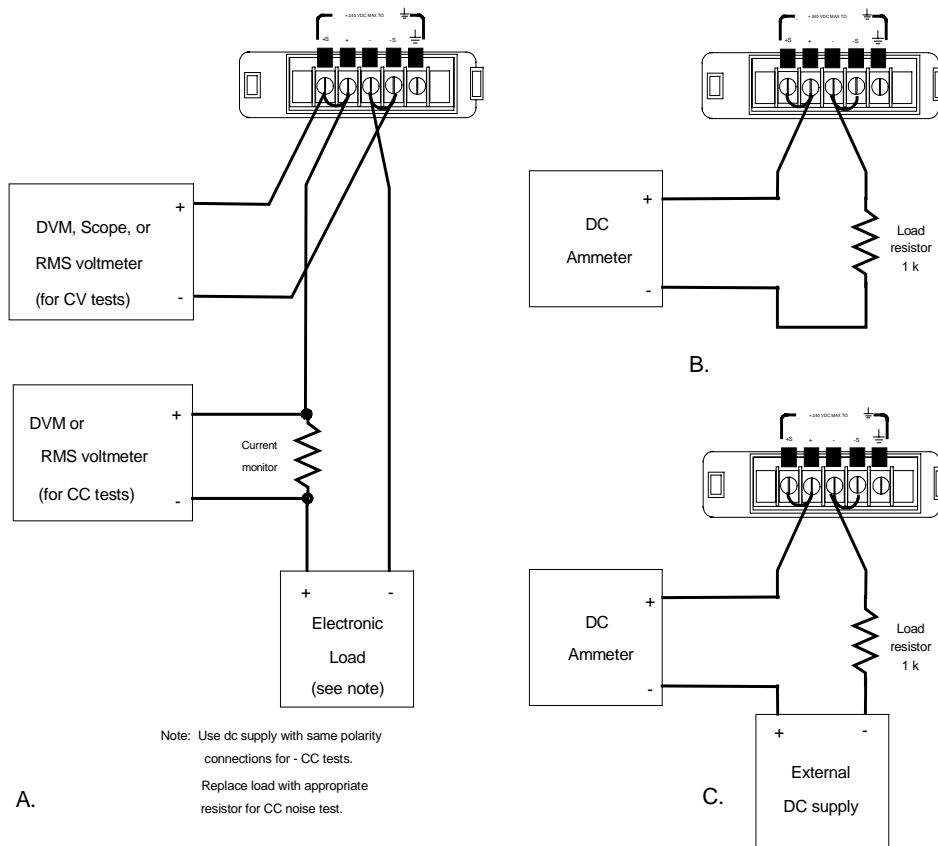

**Figure 2-1. Test Setup**

## Electronic Load

Many of the test procedures require the use of a variable load capable of dissipating the required power. If a variable resistor is used, switches should be used to either; connect, disconnect, or short the load resistor. For most tests, an electronic load can be used. The electronic load is considerably easier to use than load resistors, but it may not be fast enough to test transient recovery time and may be too noisy for the noise (PARD) tests.

Fixed load resistors may be used in place of a variable load, with minor changes to the test procedures. Also, if computer controlled test setups are used, the relatively slow (compared to computers and system voltmeters) settling times and slew rates of the power supply may have to be taken into account. "Wait" statements can be used in the test program if the test system is faster than the supply.

## Current-Monitoring Resistor

To eliminate output-current measurement error caused by voltage drops in the leads and connections, connect the current monitoring resistor between the -OUT and the load as a four-terminal device. Connect the current-monitoring leads inside the load-lead connections directly at the monitoring points on the resistor element.

---

## Operation Verification Tests

To assure that the supply is operating properly, without testing all specified parameters, perform the following test procedures:

- a. Perform the turn-on and checkout procedures given in the Operating Manual.
- b. Perform the Voltage Programming and Readback Accuracy test, and the Current Programming and Readback Accuracy tests from this procedure.

---

## Performance Tests

**NOTE:** A full Performance Test consists of only those items listed as "Specifications" in Table A-1 of the Operating Manual, and that have a procedure in this document.

---

The following paragraphs provide test procedures for verifying the supply's compliance with the specifications listed in Table A-1 of the Operating Manual. All of the performance test specifications and calculated measurement uncertainties are entered in the appropriate Performance Test Record Card for your specific model. You can record the actual measured values in the column provided in this card.

If you use equipment other than that recommended in Table 2-1, you must recalculate the measurement uncertainties for the actual equipment used.

## Programming

You can program the supply from the front panel keyboard or from a GPIB controller when performing the tests. The test procedures are written assuming that you know how to program the supply either; remotely from a GPIB controller or locally using the control keys and indicators on the supply's front panel. Complete instructions on remote and local programming are given in the User's Guide and in the Programming Guide. Programming ratings are as follows:

## 2 - Verification and Performance Tests

**Table 2-2. Programming Ratings**

Model	Voltage Rating	Full Scale Rating	Current Rating	Full Scale Rating
Agilent 66332A/6632B	20 V	20.020 V	5 A	5.0045 A
	50 V	50.045 V	2 A	2.002 A
Agilent 6633B	100 V	100.1 V	1 A	1.001 A
Agilent 6634B				

---

## Constant Voltage (CV) Tests

### CV Setup

If more than one meter or if a meter and an oscilloscope are used, connect each to the terminals by a separate pair of leads to avoid mutual coupling effects. For constant voltage dc tests, connect only to +S and -S, since the unit regulates the output voltage that appears between +S and -S, and not between the (+) and (-) output terminals. Use coaxial cable or shielded two-wire cable to avoid noise pickup on the test leads.

### Voltage Programming and Readback Accuracy

This test verifies that the voltage programming, GPIB readback and front panel display functions are within specifications. Note that the values read back over the GPIB should be identical to those displayed on the front panel.

- Turn off the supply and connect a digital voltmeter between the +S and the -S terminals as shown in Figure 2-1a.
- Turn on the supply and program the supply to zero volts and the maximum programmable current with the load off.
- Record the output voltage readings on the digital voltmeter (DVM) and the front panel display. The readings should be within the limits specified in the performance test record chart for the appropriate model under CV PROGRAMMING @ 0 VOLTS. Also, note that the CV annunciator is on. The output current reading should be approximately zero.
- Program the output voltage to full-scale.
- Record the output voltage readings on the DVM and the front panel display. The readings should be within the limits specified in the performance test record chart for the appropriate model under CV PROGRAMMING @ FULL SCALE.

### CV Load Effect

This test measures the change in output voltage resulting from a change in output current from full load to no load.

- Turn off the supply and connect the output as shown in Figure 2-1a with the DVM connected between the +S and -S terminals.
- Turn on the supply and program the current to the maximum programmable value and the voltage to the full-scale value.
- Adjust the load for the full-scale current as indicated on the front panel display. The CV annunciator on the front panel must be on. If it is not, adjust the load so that the output current drops slightly.
- Record the output voltage reading on the DVM connected to +S and -S.

- e. Open the load and again record the DVM voltage reading. The difference between the DVM readings in steps (d) and (e) is the load effect voltage, and should not exceed the value listed in the performance test record chart for the appropriate model under CV LOAD EFFECT.

## CV Source Effect

This test measures the change in output voltage that results from a change in ac line voltage from the minimum to maximum value within the line voltage specifications.

- a. Turn off the supply and connect the ac power line through a variable voltage transformer.
- b. Connect the output as shown in Figure 2-1a with the DVM connected between the +S and the -S terminals. Set the transformer to nominal line voltage.
- c. Turn on the supply and program the current to the maximum programmable value and the output voltage to the full-scale value .
- d. Adjust the load for the full-scale current value as indicated on the front panel display. The CV annunciator on the front panel must be on. If it is not, adjust the load so that the output current drops slightly.
- e. Adjust the transformer to the lowest rated line voltage (e.g., 104 Vac for a 115 Vac nominal line voltage input).
- f. Record the output voltage reading on the DVM.
- g. Adjust the transformer to the highest rated line voltage (e.g., 127 Vac for 115 Vac nominal line voltage input).
- h. Record the output voltage reading on the DVM. The difference between the DVM reading is steps (f) and (h) is the source effect voltage and should not exceed the value listed in the performance test record chart for the appropriate model under CV SOURCE EFFECT.

## CV Noise (PARD)

Periodic and random deviations (PARD) in the output (ripple and noise) combine to produce a residual ac voltage superimposed on the dc output voltage. CV PARD is specified as the rms or peak-to-peak output voltage in the frequency range specified in the User's Guide.

- a. Turn off the supply and connect the output as shown in Figure 2-1a to an oscilloscope (ac coupled) between the (+) and the (-) terminals. Set the oscilloscope's bandwidth limit to 20 MHz and use an RF tip on the oscilloscope probe.
- b. Turn on the supply and program the current to the maximum programmable value and the output voltage to the full-scale value.
- c. Adjust the load for the full-scale current value as indicated on the front panel display.
- d. Note that the waveform on the oscilloscope should not exceed the peak-to-peak limits in the performance test record chart for the appropriate model under CV NOISE (PARD).
- e. Disconnect the oscilloscope and connect an ac rms voltmeter in its place. The rms voltage reading should not exceed the RMS limits in the performance test record chart for the appropriate model under CV NOISE (PARD).

## 2 - Verification and Performance Tests

### Transient Recovery Time

This test measures the time for the output voltage to recover to within the specified value following a 50% change in the load current.

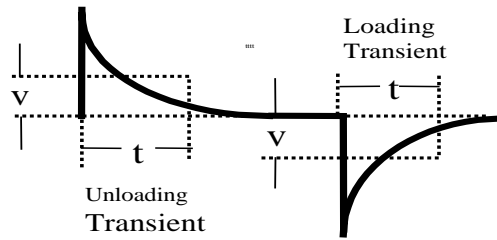

**Figure 2-2. Transient Waveform**

- Turn off the supply and connect the output as in Figure 2-1a with the oscilloscope across the +S and the -S terminals.
- Turn on the supply and program the output voltage to the full-scale value and the current to the maximum programmable value.
- Set the load to the Constant Current mode and program the load current to 1/2 the power supply full-scale rated current.
- Set the electronic load's transient generator frequency to 100 Hz and its duty cycle to 50%.
- Program the load's transient current level to the supply's full-scale current value and turn the transient generator on.
- Adjust the oscilloscope for a waveform similar to that in Figure 2-2.
- The output voltage should return to within the specified voltage (v) in less than the specified time (t). Check both loading and unloading transients by triggering on the positive and negative slope.

---

## Constant Current (CC) Tests

### CC Setup

Follow the general setup instructions in the Measurement Techniques paragraph and the specific instructions given in the following paragraphs.

### Current Programming and Readback Accuracy

This test verifies that the current programming and readback are within specification.

- Turn off the supply and connect the current monitoring resistor across the power supply output and the DVM across the resistor. See "Current Monitoring Resistor" for connection information.
- Turn on the supply and program the output voltage to 5 V and the current to zero.
- Divide the voltage drop (DVM reading) across the current monitoring resistor by its resistance to convert to amps and record this value ( $I_{out}$ ). Also, record the current reading on the front panel display. The readings should be within the limits specified in the performance test record card for the appropriate model under CC PROGRAMMING @ 0 AMPS.
- Program the output current to full-scale .



- e. Divide the voltage drop (DVM reading) across the current monitoring resistor by its resistance to convert to amps and record this value ( $I_{out}$ ). Also, record the current reading that appears on the front panel display. The readings should be within the limits specified in the performance test record card for the appropriate model under CC PROGRAMMING @ FULL-SCALE.

## Current Sink (-CC) Operation

This test verifies current sink operation and readback.

- a. Turn off the supply and connect the output as shown in Figure 2-1a, except connect a dc power supply in place of the electronic load as indicated. Connect the DMM across the current shunt.
- b. Set the external power supply to 5 V and the current limit approximately 20% above the full scale current rating of the supply under test.
- c. Turn on the supply under test and program the output voltage to zero and full scale output current. The current on the UUT display should be approximately full scale current negative.
- d. Divide the voltage drop across the current monitoring resistor by its resistance to obtain the current sink value in amps and subtract this from the current reading on the display. The difference between the readings should be within the limits specified in the performance test record chart under CURRENT SINK READBACK.

## Low Range Current Readback Accuracy

This test verifies the readback accuracy of the 20 milliamperere current range.

- a. Turn off the supply and connect the output as shown in Figure 2-1b. Set the DMM to operate in current mode.
- b. Turn on the supply under test and program the output voltage to zero and full scale output current. The current on the UUT display should be approximately 0 mA.
- c. Record the current reading on the DMM and the reading on the front panel display. The difference between the two readings should be within the limits specified in the performance test record chart under 20mA RANGE CURRENT READBACK ACCURACY @ 0A.
- d. Program the output voltage to 20V and record the current reading on the DMM and the reading on the front panel display. The difference between the readings should be within the limits specified in the performance test record chart for the appropriate model under 20mA RANGE CURRENT READBACK ACCURACY @ 20mA
- e. Turn off the supply and connect the output and an external supply as shown in Figure 2-1c. Set the DMM to operate in current mode.
- f. Turn on the external supply and program it to 20 V and 1 amp. Then program the supply under test to zero volts and 1 amp. The UUT display should read approximately -20 mA.
- c. Record the current reading on the DMM and the reading on the front panel display. The difference between the two readings should be within the limits specified in the performance test record chart under 20mA RANGE CURRENT READBACK ACCURACY @ -20 mA.

## CC Load and Line Regulation

These tests (CC Load Effect and CC Source Effect given below) are tests of the dc regulation of the power supply's output current. To insure that the values read are not the instantaneous measurement of the ac peaks of the output current ripple, several dc measurements should be made and the average of these readings calculated. An example of how to do this is given below using an Agilent 3458A System Voltmeter programmed from the front panel. Set up the voltmeter and execute the "Average Reading" program follows:

- a. Program 10 power line cycles per sample by pressing NPLC 1 0 ENTER .
- b. Program 100 samples per trigger by pressing (N Rdgs/Trig) 1 0 0 ENTER .

## 2 - Verification and Performance Tests

- c. Set up voltmeter to take measurements in the statistical mode as follows:  
Press Shift key, f0, Shift key, N  
Press ^ (up arrow) until MATH function is selected, then press >.  
Press ^ (up arrow) until STAT function is selected then press (ENTER).
- d. Set up voltmeter to read the average of the measurements as follows:  
Press Shift key, f1, Shift key, N.  
Press down arrow until RMATH function is selected, then press >.  
Press ^ (up arrow) until MEAN function is selected, then press ENTER.
- e. Execute the program by pressing f0, ENTER, TRIG, ENTER
- f. Wait for 100 readings and then read the average measurement by pressing f1, ENTER.

To repeat the measurement, perform steps (e) and (f).

### CC Load Effect

This test measures the change in output current for a change in load from full scale output voltage to short circuit.

- a. Turn off the supply and connect the output as shown in Figure 2-1a with the DVM connected across the current monitoring resistor.
- b. Turn on the supply and program the current to the full scale current value and the output voltage to the maximum programmable voltage value.
- c. Adjust the load in the CV mode for full scale voltage as indicated on the front panel display. Check that the CC annunciator of the UUT is on. If it is not, adjust the load so that the output voltage drops slightly.
- d. Record the output current reading (DVM reading/current monitor resistance value in ohms). You may want to use the average reading program described under “CC Load and Line Regulation”.
- e. Short the load switch and record the output current reading. The difference in the current readings in steps (d) and (e) is the load effect and should not exceed the limit specified in the performance test record chart for the appropriate model under CC LOAD EFFECT.

### CC Source Effect

This test measures the change in output current that results when the AC line voltage changes from the minimum to the maximum value within the specifications.

- a. Turn off the supply and connect the ac power line through a variable voltage transformer.
- b. Connect the output terminals as shown in Figure 2-1a with the DVM connected across the current monitoring resistor. Set the transformer to the nominal line voltage.
- c. Turn on the supply and program the current to the full scale value and the output voltage to the maximum programmable value.
- d. Adjust the load in the CV mode for full scale voltage as indicated on the front panel display. Check that the CC annunciator of the UUT is on. If it is not, adjust the load so that the output voltage drops slightly.
- e. Adjust the transformer to the lowest rated line voltage.
- f. Record the output current reading (DVM reading/current monitoring resistor in ohms). You may want to use the average reading program described under “CC Load and Line Regulation”.
- g. Adjust the transformer to the highest rated line voltage.
- h. Record the output current reading again. The difference in the current readings in steps (f) and (h) is the CC source effect and should not exceed the values listed in the performance test record card under CC SOURCE EFFECT.

### CC Noise (PARD)

Periodic and random deviations (PARD) in the output combine to produce a residual ac current, as well, as an ac voltage superimposed on the dc output. Constant current (CC) PARD is specified as the rms output current in a frequency range 20 Hz to 20 Mhz with the supply in CC operation.

- a. Turn off the supply and connect the load, monitoring resistor, and rms voltmeter across the monitoring resistor as shown in Figure 2-1a. The Current Monitoring resistor may have to be substituted by one with a higher resistance and power rating, such as a 1 ohm 50 W current shunt in series with the appropriate 3, 24, or 99 ohm resistor, to get the RMS voltage drop high enough to measure with the RMS voltmeter. Leads should be as short as possible to reduce noise pick-up. An electronic load may contribute ripple to the measurement so if the RMS noise is above the specification a resistive load may have to be substituted for this test.
- b. Check the test setup for noise with the supply turned off. Other equipment (e.g. computers, DVMs, etc.) may affect the reading.
- c. Turn on the supply and program the current to full scale and the output voltage to the maximum programmable value.
- d. The output current should be at the full scale rating with the CC annunciator on.
- e. Divide the reading on the rms voltmeter by the monitor resistor to obtain rms current. It should not exceed the values listed in the performance test record card under CC NOISE (RMS).

## Performance Test Equipment Form

Test Facility: _____	Report Number _____
_____	Date _____
_____	Customer _____
_____	Tested By _____
Model _____	Ambient Temperature (C) _____
Serial No. _____	Relative Humidity (%) _____
Options _____	Nominal Line Frequency _____
Firmware Revision _____	

**Special Notes:**

**Test Equipment Used:**

Description	Model No.	Trace No.	Cal. Due Date
AC Source	_____	_____	_____
DC Voltmeter	_____	_____	_____
RMS Voltmeter	_____	_____	_____
Oscilloscope	_____	_____	_____
Electronic Load	_____	_____	_____
Current Shunt	_____	_____	_____

## Performance Test Record Forms

Model Agilent 66332A OR Agilent6632B	Report No _____	Date _____		
Test Description	Minimum Specs.	Results*	Maximum Specs.	Measurement Uncertainty
<b>Constant Voltage Tests</b>				
<b>Voltage Programming and Readback</b>				
Low Voltage (0V) Vout	- 10 mV	_____	+ 10 mV	1.6 $\mu$ V
Front Panel Display Readback	<b>Vout</b> - 3 mV	_____	<b>Vout</b> + 3 mV	1.6 $\mu$ V
High Voltage (Full Scale) Vout	19.980 V	_____	20.020 V	335 $\mu$ V
Front Panel Display Readback	<b>Vout</b> - 9 mV	_____	<b>Vout</b> + 9 mV	335 $\mu$ V
<b>Load Effect</b>	- 2 mV	_____	+ 2 mV	20 $\mu$ V
<b>Source Effect</b>	- 0.5 mV	_____	+ 0.5 mV	20 $\mu$ V
<b>PARD (Ripple and Noise)</b>				
Peak-to-Peak	0 mV	_____	+ 3 mV	872 $\mu$ V
RMS	0 mV	_____	+ 0.3 mV	50 $\mu$ V
<b>Transient Response</b>				
Voltage in 100 $\mu$ s	0 mV	_____	+ 20 mV	3 mV
<b>Constant Current Tests</b>				
<b>Current Programming and Readback</b>				
Low current (0A) Iout	- 2.0 mA	_____	+ 2.0 mA	15.2 $\mu$ A
Readback Accuracy @ Iout	<b>Iout</b> - 0.5 mA	_____	<b>Iout</b> + 0.5 mA	15.2 $\mu$ A
High Current (Full Scale) Iout	4.9955 A	_____	5.0045 A	818.7 $\mu$ A
Readback Accuracy @ Iout	<b>Iout</b> - 10.5 mA	_____	<b>Iout</b> + 10.5 mA	818.7 $\mu$ A
<b>Current Sink Readback</b>	<b>Isink</b> - 11.1mA	_____	<b>Isink</b> + 11.1mA	818.7 $\mu$ A
<b>20 mA Range Current Readback</b>				
Readback Accuracy @ 0 A	- 2.5 $\mu$ A	_____	+ 2.5 $\mu$ A	0.1 $\mu$ A
Readback Accuracy @ + 20 mA	<b>Iout</b> - 22.5 $\mu$ A	_____	<b>Iout</b> + 22.5 $\mu$ A	1.7 $\mu$ A
Readback Accuracy @ - 20 mA	<b>Iout</b> - 22.5 $\mu$ A	_____	<b>Iout</b> + 22.5 $\mu$ A	1.7 $\mu$ A
<b>PARD (Current Ripple and Noise)</b>				
RMS	0 mA	_____	+ 2.0 mA	250 $\mu$ A
<b>Load Effect</b>	- 1.0 mA	_____	+ 1.0 mA	2.5 $\mu$ A
<b>Source Effect</b>	- 0.5 mA	_____	+ 0.5 mA	2.5 $\mu$ A

\* Enter your test results in this column

Model <b>Agilent 6633B</b>	Report No _____		Date _____	
Test Description	Minimum Specs.	Results*	Maximum Specs.	Measurement Uncertainty
<b>Constant Voltage Tests</b>				
<b>Voltage Programming and Readback</b>				
Low Voltage (0V) Vout	- 20 mV	_____	+ 20 mV	1.7 $\mu$ V
Front Panel Display Readback	<b>Vout</b> - 6 mV	_____	<b>Vout</b> + 6 mV	1.7 $\mu$ V
High Voltage (Full Scale) Vout	49.955 V	_____	50.045 V	717.5 $\mu$ V
Front Panel Display Readback	<b>Vout</b> - 21 mV	_____	<b>Vout</b> + 21 mV	717.5 $\mu$ V
<b>Load Effect</b>	- 4 mV	_____	+ 4 mV	35 $\mu$ V
<b>Source Effect</b>	- 1.0 mV	_____	+ 1.0 mV	35 $\mu$ V
<b>PARD (Ripple and Noise)</b>				
Peak-to-Peak	0 mV	_____	+ 3 mV	872 $\mu$ V
RMS	0 mV	_____	+ 0.5 mV	50 $\mu$ V
<b>Transient Response</b>				
Voltage in 100 $\mu$ s	0 mV	_____	+ 50 mV	8 mV
<b>Constant Current Tests</b>				
<b>Current Programming and Readback</b>				
Low current (0A) Iout	- 1.0 mA	_____	+ 1.0 mA	15.1 $\mu$ A
Readback Accuracy @ Iout	<b>Iout</b> - 0.25 mA	_____	<b>Iout</b> + 0.25 mA	15.1 $\mu$ A
High Current (Full Scale) Iout	1.998 A	_____	2.002 A	252.5 $\mu$ A
Readback Accuracy @ Iout	<b>Iout</b> - 4.3 mA	_____	<b>Iout</b> + 4.3 mA	252.5 $\mu$ A
<b>Current Sink Readback</b>	<b>Isink</b> - 4.9 mA	_____	<b>Isink</b> + 4.9 mA	252.5 $\mu$ A
<b>20 mA Range Current Readback</b>				
Readback Accuracy @ 0 A	- 2.5 $\mu$ A	_____	+ 2.5 $\mu$ A	0.1 $\mu$ A
Readback Accuracy @ + 20 mA	<b>Iout</b> - 22.5 $\mu$ A	_____	<b>Iout</b> + 22.5 $\mu$ A	1.7 $\mu$ A
Readback Accuracy @ - 20 mA	<b>Iout</b> - 22.5 $\mu$ A	_____	<b>Iout</b> + 22.5 $\mu$ A	1.7 $\mu$ A
<b>PARD (Current Ripple and Noise)</b>				
RMS	0 mA	_____	+ 2.0 mA	250 $\mu$ A
<b>Load Effect</b>	- 1.0 mA	_____	+ 1.0 mA	1.6 $\mu$ A
<b>Source Effect</b>	- 0.25 mA	_____	+ 0.25 mA	1.6 $\mu$ A

\* Enter your test results in this column

## 2 - Verification and Performance Tests

Model <b>Agilent 6634B</b>	Report No _____		Date _____	
Test Description	Minimum Specs.	Results*	Maximum Specs.	Measurement Uncertainty
<b>Constant Voltage Tests</b>				
<b>Voltage Programming and Readback</b>				
Low Voltage (0V) Vout	- 50 mV	_____	+ 50 mV	2.1 $\mu$ V
Front Panel Display Readback	<b>Vout</b> - 12 mV	_____	<b>Vout</b> + 12 mV	2.1 $\mu$ V
High Voltage (Full Scale) Vout	99.9 V	_____	100.1 V	1.4 mV
Front Panel Display Readback	<b>Vout</b> - 42 mV	_____	<b>Vout</b> + 42 mV	1.4 mV
<b>Load Effect</b>	- 5 mV	_____	+ 5 mV	60 $\mu$ V
<b>Source Effect</b>	- 1 mV	_____	+ 1 mV	60 $\mu$ V
<b>PARD (Ripple and Noise)</b>				
Peak-to-Peak	0 mV	_____	+ 3 mV	872 $\mu$ V
RMS	0 mV	_____	+ 0.5 mV	50 $\mu$ V
<b>Transient Response</b>				
Time in 100 $\mu$ s	0 mV	_____	+ 100 mV	15 mV
<b>Constant Current Tests</b>				
<b>Current Programming and Readback</b>				
Low current (0A) Iout	- 0.5 mA	_____	+ 0.5 mA	15.1 $\mu$ A
Readback Accuracy @ Iout	<b>Iout</b> - 0.25 mA	_____	<b>Iout</b> + 0.25 mA	15.1 $\mu$ A
High Current (Full Scale) Iout	0.999 A	_____	1.001 A	128.8 $\mu$ A
Readback Accuracy @ Iout	<b>Iout</b> - 2.3 mA	_____	<b>Iout</b> + 2.3 mA	128.8 $\mu$ A
<b>Current Sink Readback</b>	<b>Isink</b> - 2.9 mA	_____	<b>Isink</b> + 2.9 mA	128.8 $\mu$ A
<b>20 mA Range Current Readback</b>				
Readback Accuracy @ 0 A	- 2.5 $\mu$ A	_____	+ 2.5 $\mu$ A	0.1 $\mu$ A
Readback Accuracy @ + 20 mA	<b>Iout</b> - 22.5 $\mu$ A	_____	<b>Iout</b> + 22.5 $\mu$ A	1.7 $\mu$ A
Readback Accuracy @ - 20 mA	<b>Iout</b> - 22.5 $\mu$ A	_____	<b>Iout</b> + 22.5 $\mu$ A	1.7 $\mu$ A
<b>PARD (Current Ripple and Noise)</b>				
RMS	0 mA	_____	+ 2.0 mA	250 $\mu$ A
<b>Load Effect</b>	- 1.0 mA	_____	+ 1.0 mA	1 $\mu$ A
<b>Source Effect</b>	- 0.25 mA	_____	+ 0.25 mA	1 $\mu$ A

\* Enter your test results in this column

# Troubleshooting

---

## Introduction

---

**WARNING:**     **SHOCK HAZARD.** Most of the troubleshooting procedures given in this chapter are performed with power applied and protective covers removed. Such maintenance should be performed only by service trained personnel who are aware of the hazards (for example, fire and electrical shock).

---

**CAUTION:**     This instrument uses components which can either be damaged or suffer serious performance degradation as a result of ESD (electrostatic discharge). Observe the standard antistatic precautions to avoid damage to the components. An ESD summary is given in Chapter 1.

---

This chapter provides troubleshooting and repair information for the dc power supply. Before attempting to troubleshoot the dc power supply, first check that the problem is with the supply itself and not with an associated circuit. The verification tests in Chapter 2 enable you to isolate a problem to the dc power supply. Troubleshooting procedures are provided to isolate a problem to one of the circuit boards or a particular circuit. Figure 3-2 shows the location of the circuit boards and other major components of the unit. If a problem has been isolated to the A1 Control circuit board, additional troubleshooting procedures are available to isolate the problem to the defective component(s). Disassembly procedures are provided at the end of this chapter and should be referred to, as required, in order to gain access to and/or replace defective components.

If a component is defective, replace it and then conduct the verification test given in Chapter 2.

---

**NOTE:**     Note that when certain components are replaced, the supply must be calibrated (See "Post Repair Calibration" later in this chapter). If the A2 Interface Board is replaced, the supply must be initialized before it is calibrated. See "Initialization" later in this chapter.

---

Chapter 5 lists all of the replaceable parts for the power supplies. Chapter 6 contains schematics, test point measurements, and component location diagrams to aid you in troubleshooting the supply.

---

## Test Equipment Required

Table 3-1 lists the test equipment required to troubleshoot the power supply. Recommended models are listed.

**Table 3-1. Test Equipment Required for Troubleshooting**

Type	Purpose	Recommended Model
GPIB Controller	To communicate with the supply via the GPIB interface	HP Series 300
Digital Voltmeter	To check various voltage levels	Agilent 3458A
Oscilloscope	To check waveforms and signal levels	Agilent 54504A/54111A
Electronic Load	To test operation of current circuit	Agilent 6060B
IC Test Clips	To access IC pins	AP Products No. LTC
Ammeter/Current Shunt	To measure output current	Guildline 9230/15

---

## Overall Troubleshooting

Overall troubleshooting procedures for the power supply are given in the Figure 3-1. The procedures first check that neither an AC input, nor a bias supply failure is causing the problem and that the supply passes the turn-on self test (error annunciator stays off). The normal turn-on, self-test indications are described in the "Checkout Procedure" in Chapter 3 of the User's Guide.

If the supply passes the self test and there are no obvious faults, you should perform the verification procedures in Chapter 2 from the front panel to determine if any functions are not calibrated or are not operating properly. Then program and read back a voltage via the GPIB to see if the supply responds properly to bus commands. If the supply fails any of the tests, you will be directed to the applicable flow chart or troubleshooting procedure.

### Flow Charts

Troubleshooting flow charts are given in Figure 3-1 sheets 1-10. Several flow charts make reference to the test points listed in Chapter 6. The circuit locations of the test points are shown on the schematics and on the component location diagrams in Chapter 6.



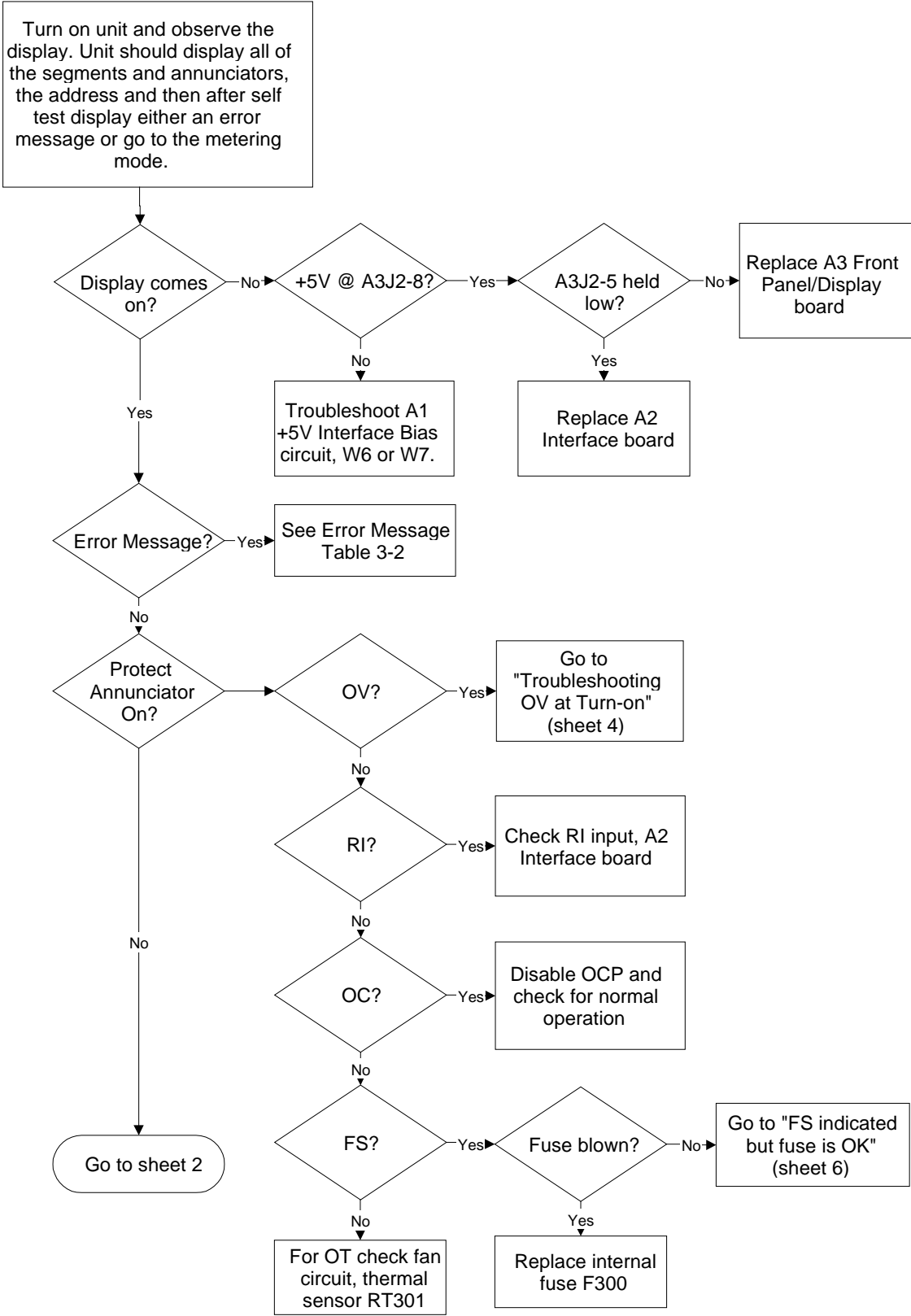

Figure 3-1 Sheet 1. Main Flowchart

### 3 - Troubleshooting

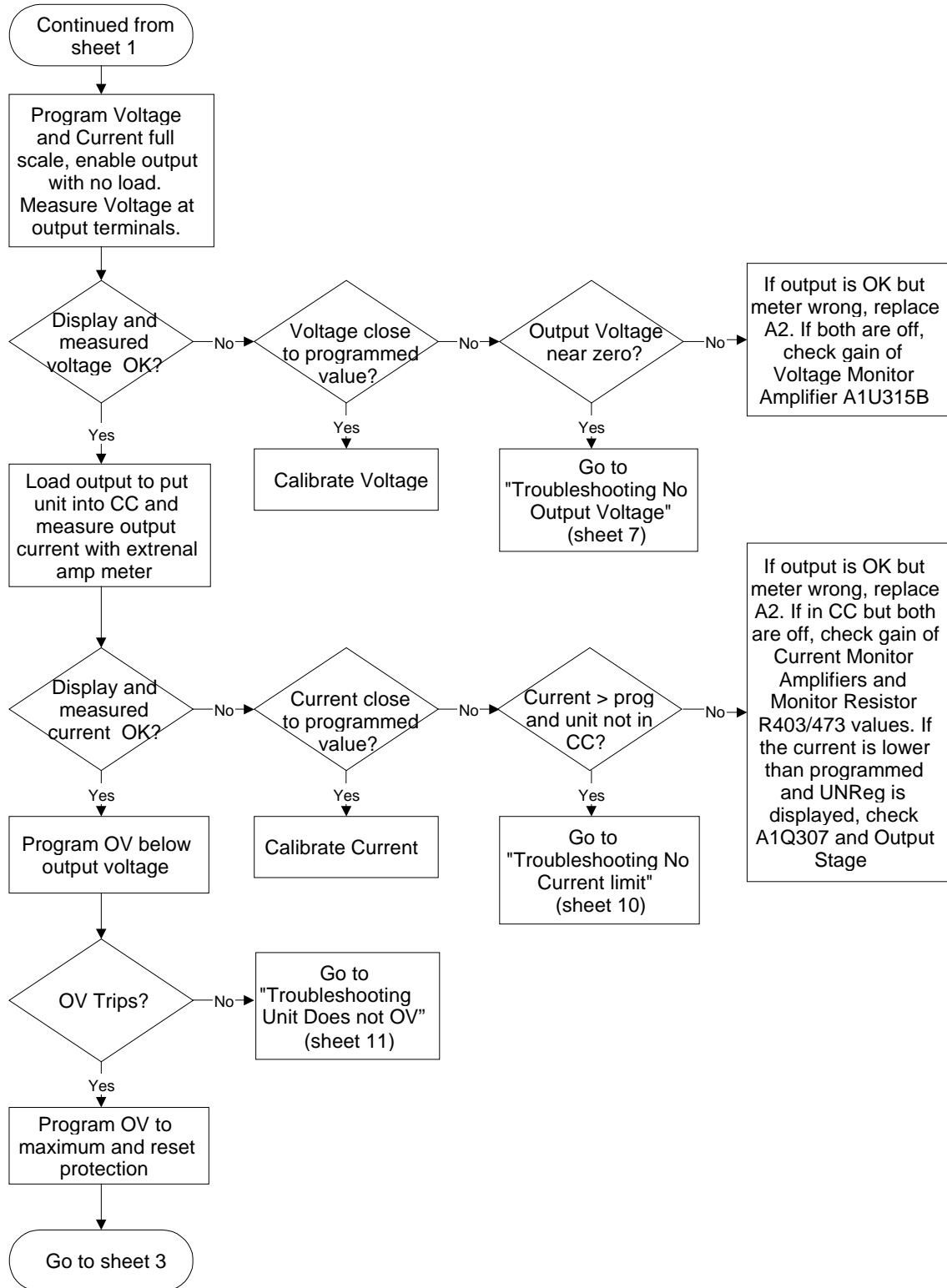

Figure 3-1 Sheet 2. Main Flowchart (continued)

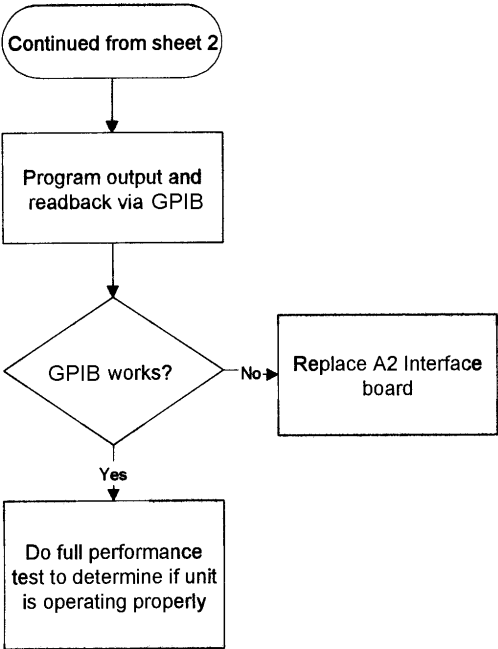

Figure 3-1 Sheet 3. Main Flowchart (continued)

### 3 - Troubleshooting

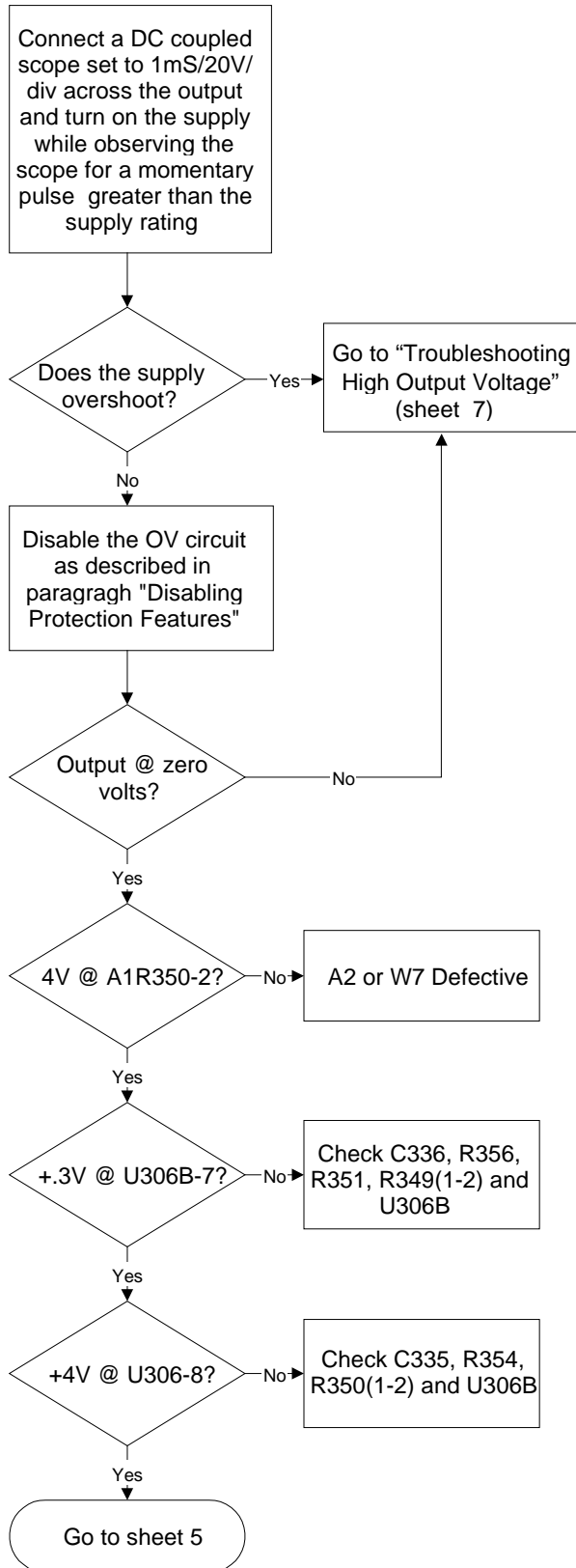

Figure 3-1 Sheet 4. OV at Turn-On

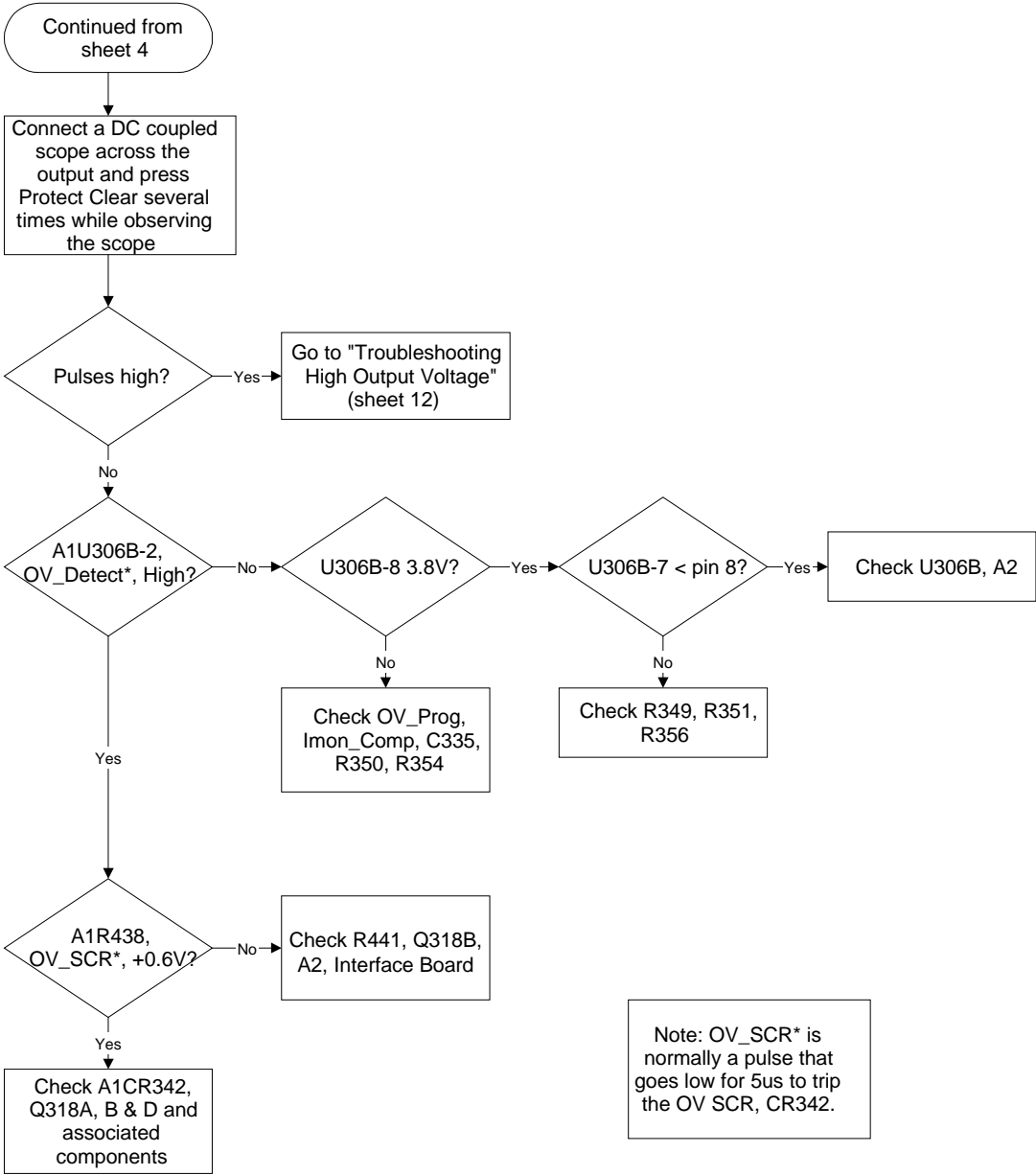

Figure 3-1 Sheet 5. OV at Turn-On (continued)

### 3 - Troubleshooting

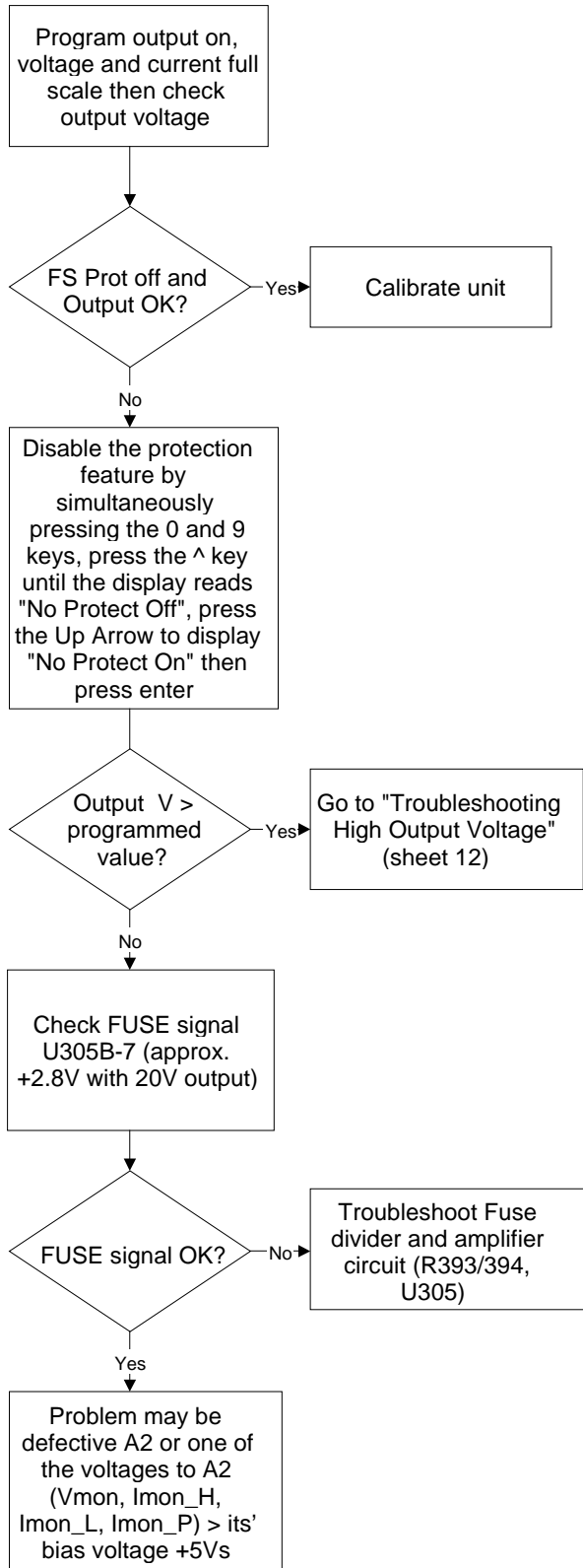

Figure 3-1 Sheet 6. FS Indicated but Fuse OK

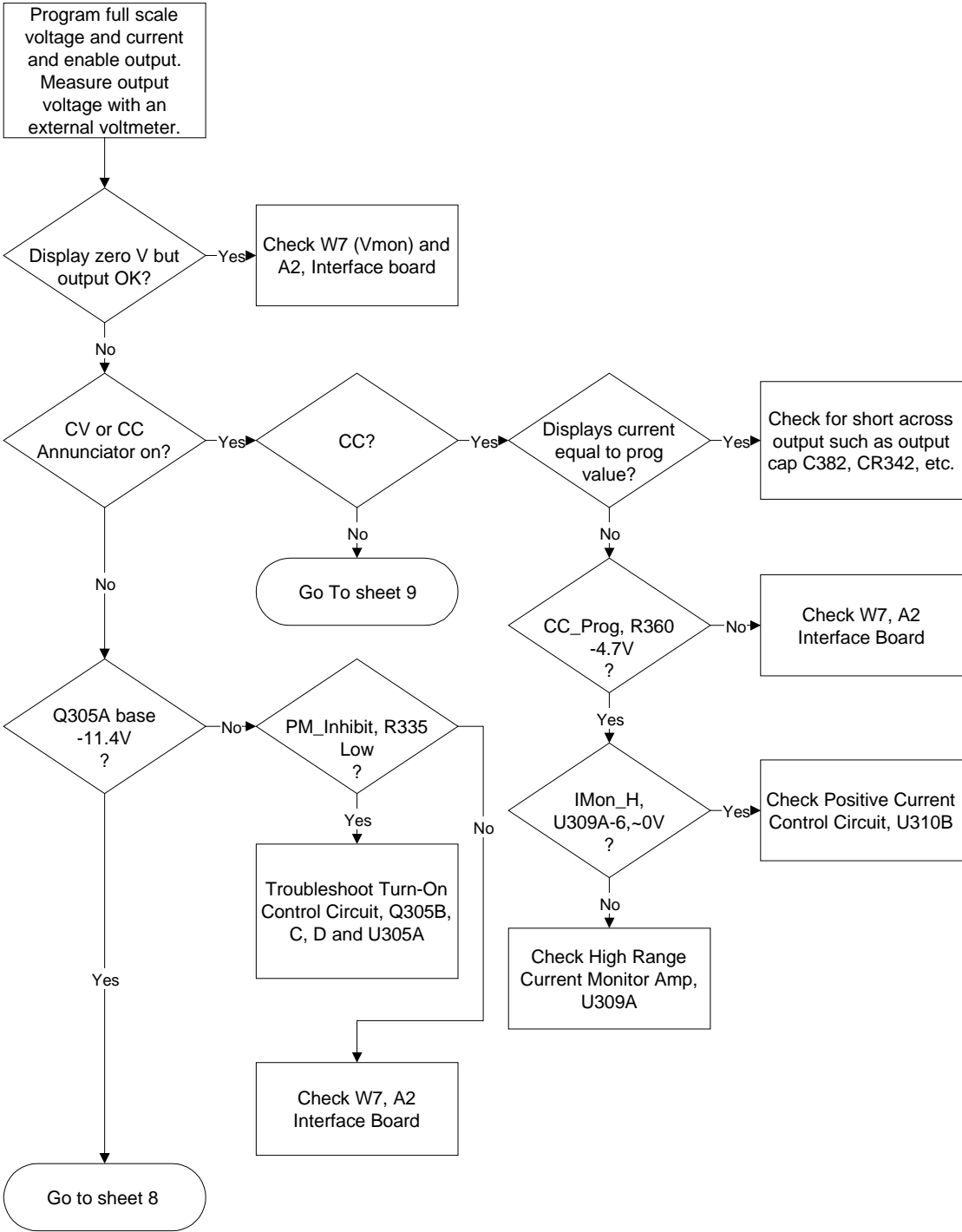

Figure 3-1 Sheet 7. No Output Voltage

### 3 - Troubleshooting

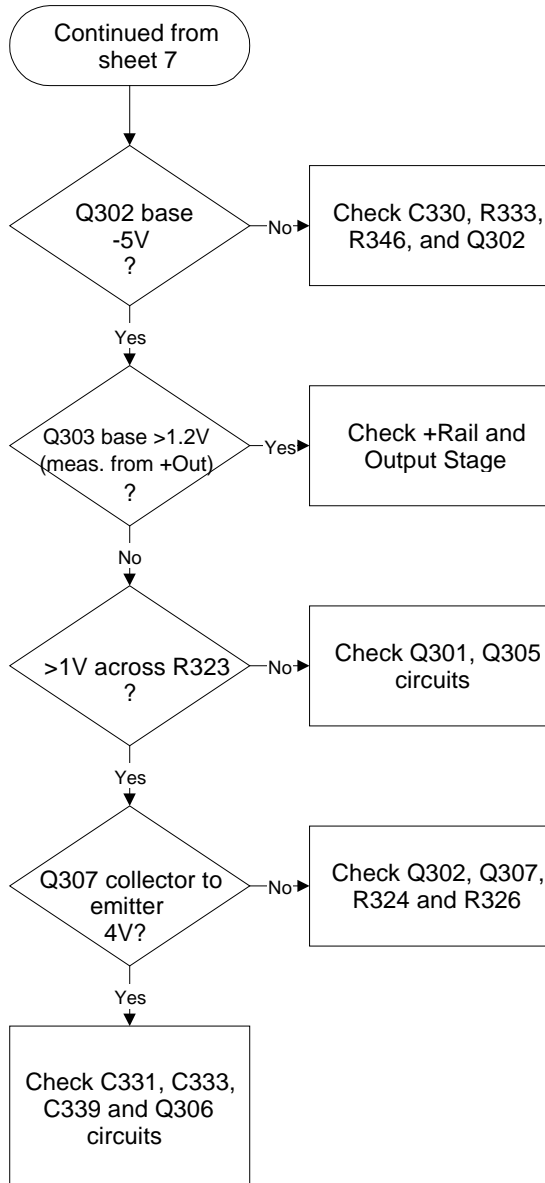

Figure 3-1 Sheet 8. No Output Voltage (continued)



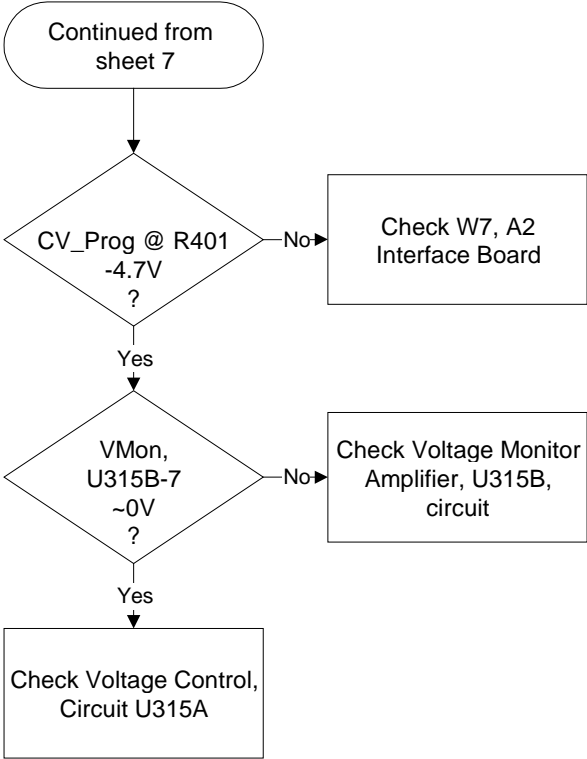

Figure 3-1 Sheet 9 No Output Voltage (continued)

### 3 - Troubleshooting

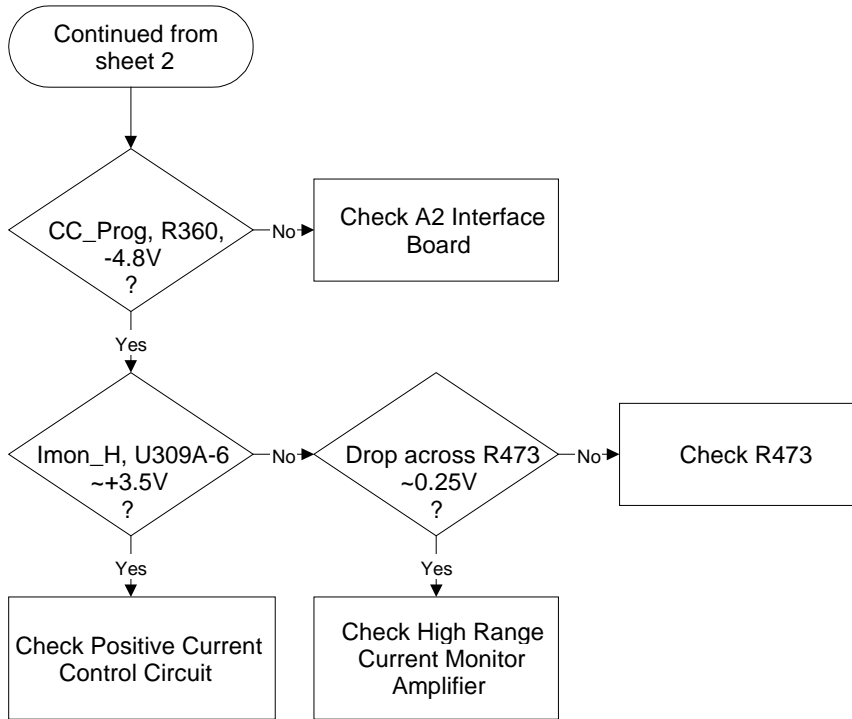

Figure 3-1 Sheet 10. No Current Limit

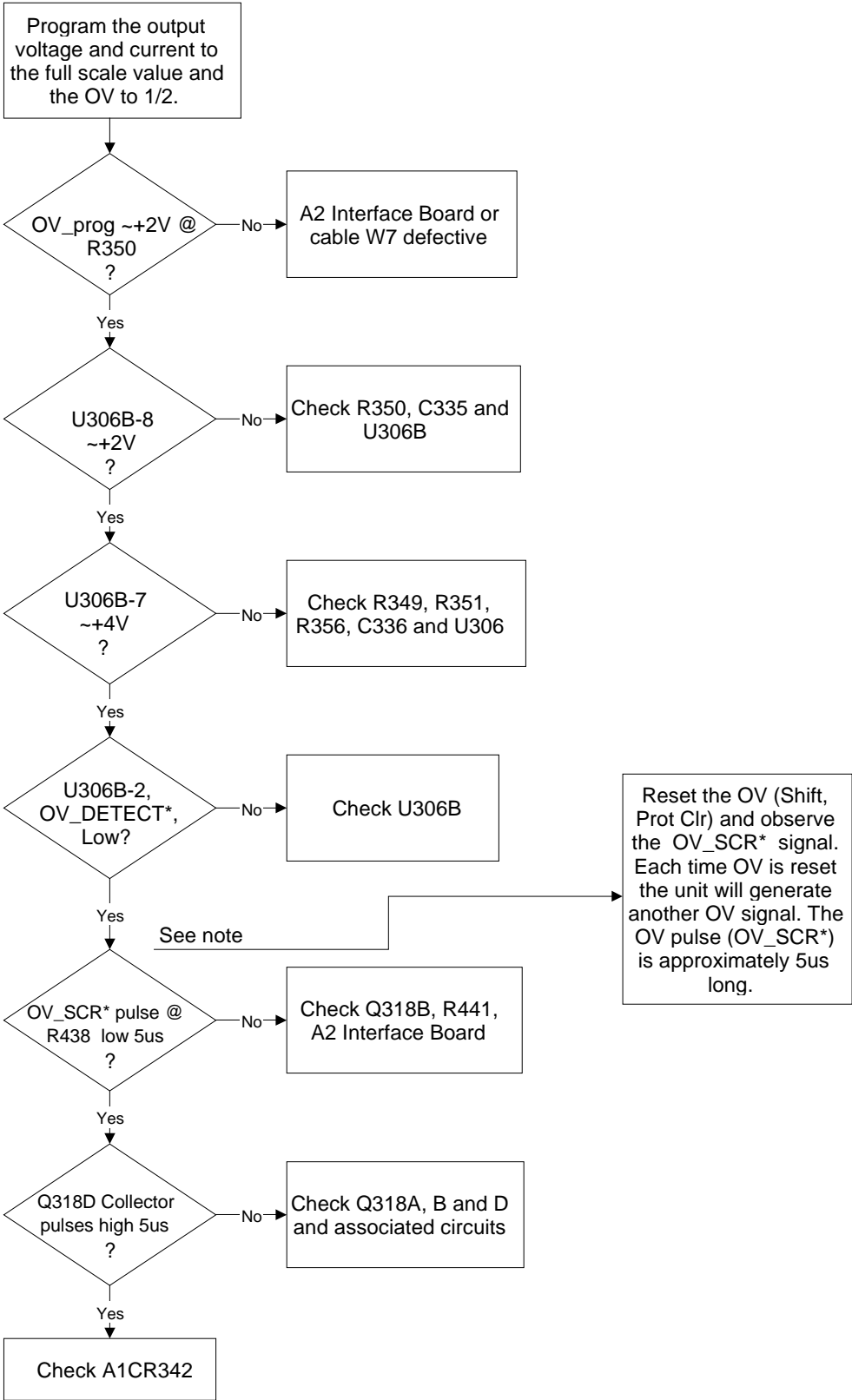

Figure 3-1 Sheet 11. Unit Does Not OV

### 3 - Troubleshooting

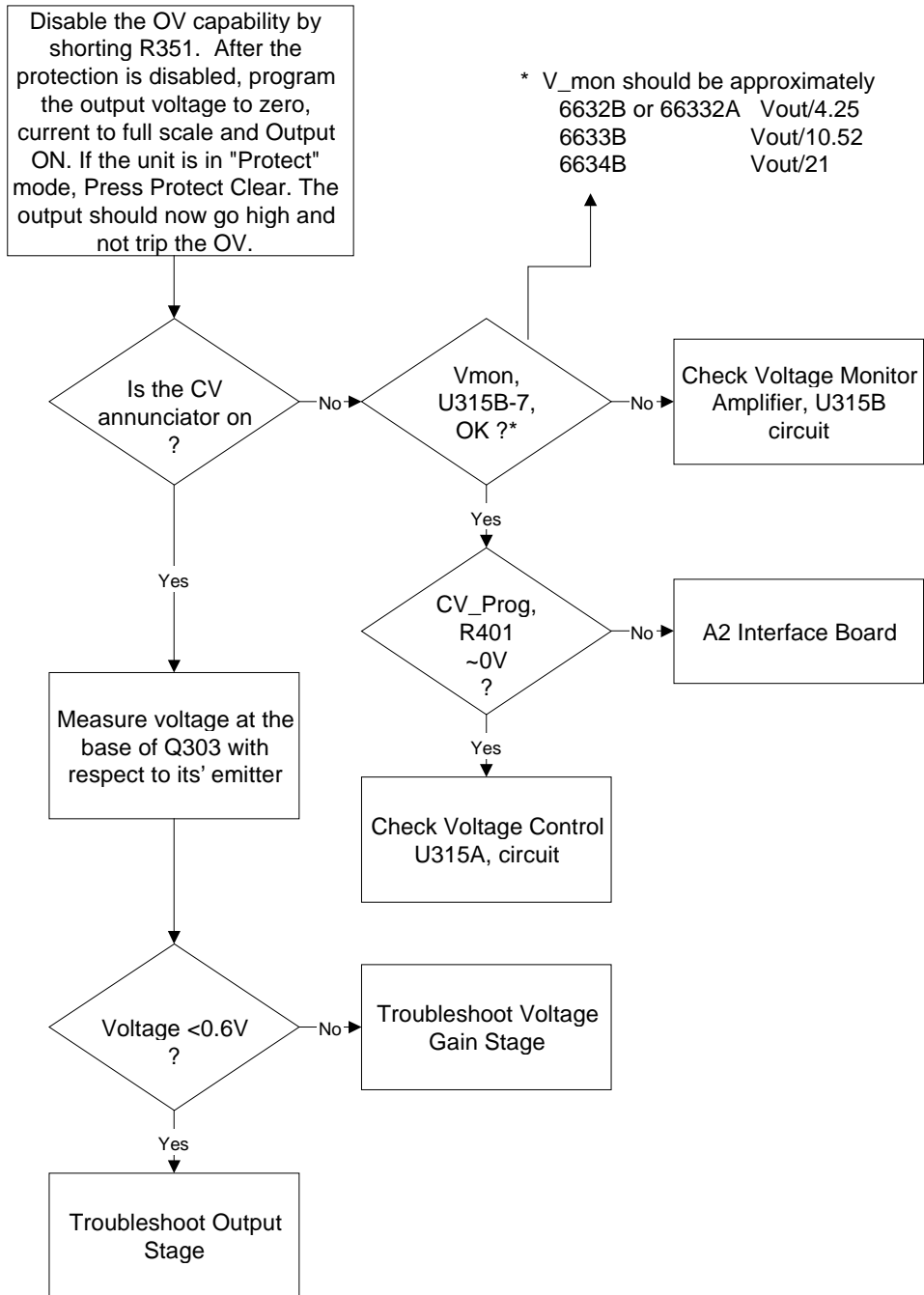

Figure 3-1 Sheet 12. High Output Voltage

## Specific Troubleshooting Procedures

### Power-on Self-test Failures

The power-on self-test sequence tests most of the digital and DAC circuits. If the supply fails self-test, the display "ERR" annunciator will come on. You can then query the unit to find out what the error(s) are. When an error is detected, the output is not disabled so you can still attempt to program the supply to help troubleshoot the unit. Table 3-2 lists the self test errors and gives the probable cause for each error.

**NOTE:** A partial self test is performed when the \*TST? query is executed. Those tests that interfere with normal interface operation or cause the output to change are not performed by \*TST?. The return value of \*TST? will be zero if all tests pass, or the error code of the first test that failed. The power supply will continue normal operation if \*TST? returns a non-zero value.

**Table 3-2. Self-Test Error Codes/Messages**

Error Code	Description	Probable Cause
E1	Checksum in Read-only Non-volatile ROM	A2 Interface Bd
E2	Checksum in Config Non-volatile ROM	A2 Interface Bd
E3	Checksum in Cal Non-volatile ROM	A2 Interface Bd
E4	Checksum in State Non-volatile ROM	A2 Interface Bd
E5	Checksum in RST Non-volatile ROM	A2 Interface Bd
E10	RAM test failed	A2 Interface Bd
E11	12 bit DAC test failed, 0 is written to DAC U241A and B, ADC U242 is checked for 133 +/- 7 counts	A2 Interface Bd
E12	12 bit DAC test failed, 4095 is written to DAC U241A and 0 to B, ADC U242 is checked for 71 +/- 7 counts	A2 Interface Bd
E13	12 bit DAC test failed, 0 is written to DAC U241A and 4095 to B, ADC U242 is checked for 71 +/- 7 counts	A2 Interface Bd
E14	12 bit DAC test failed, 4095 is written to DAC U241A and B, ADC U242 is checked for 10 +/- 7 counts	A2 Interface Bd
E15	8 bit DAC test failed, 10 and 240 are written to DAC U244, ADC U242 is checked for 10 and 240 +/- 7 counts	A2 Interface Bd
E80	Dig I/O test failed, SEC_PCLR written low and high, read back through Xilinx	A2 Interface Bd
E213	RS-232 input buffer overrun	A2 Interface Bd
E216	RS-232 framing error	A2 Interface Bd
E217	RS-232 parity error	A2 Interface Bd
E218	RS-232 UART input overrun	A2 Interface Bd
E220	Front Panel comm UART input overrun	A3 Front Panel/Display Bd
E221	Front Panel comm UART framing error	A3 Front Panel/Display Bd
E222	Front Panel comm UART parity error	A3 Front Panel/Display Bd
E223	Front Panel firmware input buffer overrun	A3 Front Panel/Display Bd

### 3 - Troubleshooting

## CV/CC Status Annunciators Troubleshooting

The CV/CC annunciators are particularly helpful when troubleshooting a unit with no output. If the unit has no output voltage or current and one of the annunciators is on then the problem is in the control circuit associated with that annunciator. An example of how this might be useful would be in a case where the voltage and current are programmed to some positive value, there is no output voltage and the CV annunciator is on. This indicates that the problem is probably in the Voltage Amplifier circuit. If the CC annunciator were on then the problem would likely be in the Current Amplifier. If UNR is indicated then neither the voltage nor the current circuits are in control and the problem would be in circuits after the gating diodes such as the driver or output regulator stages.

When troubleshooting the CV/CC status annunciators or the status readback circuits, first measure the voltage drop across the gating diodes; A1 D328 (CV) and D325 (CC). A conducting diode indicates an active (ON) control circuit. This forward drop is applied to the input of the associated status comparator (U306A and D respectively) and drives the output (CV\_DETECT\* or CC\_DETECT\*) low. The low signal indicates an active status which is sent to the A2 board microprocessor. The front panel CV annunciator indicates when the CV mode is active (CV\_DETECT\* is low). The front panel CC annunciator indicates when the CC mode is active (CC\_DETECT\* is low). The UNREGULATED (UNR) annunciator comes on when neither the CV nor CC is active.

## Bias and Rail Voltages

Before troubleshooting any circuit check the bias and/or rail voltages to make sure that they are not the cause. Table 3-3 lists the bias and rail voltage test points for the A1 Main Control, A2 Interface, and the A3 Front Panel/Display boards. Unless otherwise noted, all voltages are measured with respect to secondary common (R473-3) with no load on the supply.

**Table 3-3. Bias and Reference Voltages**

Bias	Test Point (See Figure 6-1)	Common	Measurement
+Rail <sup>1</sup> (Agilent 6632B/66332B)	A1 TP 310	- Output	+38V 10% (800mV P/P)
+Rail <sup>1</sup> (Agilent 6633B)	A1 TP 310	- Output	+73V 10% (2.5V P/P)
+Rail <sup>1</sup> (Agilent 6634B)	A1 TP 310	- Output	+130V 10% (2.2V P/P)
-Rail <sup>1</sup> (Agilent 6632B/66332B)	A1 TP 311	- Output	-9.8V 10% (400mV P/P)
-Rail <sup>1</sup> (Agilent 6633B)	A1 TP 311	- Output	-10.2V 10% (300mV P/P)
-Rail <sup>1</sup> (Agilent 6634B)	A1 TP 311	- Output	-10.5V 10% (300mV P/P)
+5V secondary	A1 R317	Secondary Common	+5V 4%
+12V secondary	A1 D470 cathode	Secondary Common	+12V 5%
+15V secondary	A1 R318	Secondary Common	+15V 4%
-12V secondary	A1 D471 anode	Secondary Common	-12V 5%
-15V secondary	A1 R315	Secondary Common	-15V 4%
V_Ref	A1 R475	Secondary Common	+2.5V 6%
+5V Interface <sup>2</sup>	E306 (red wire)	E 306 (black wire)	+5V 3%

<sup>1</sup> Measured with respect to - Output at nominal ac input line voltage

<sup>2</sup> Measured with reference to Interface Ground (E306 black wire)

## J307 Voltage Measurements

J307 connects the A1 Main Board Assembly to the A2 Interface Assembly. Table 3-4 provides a quick method of determining if the voltages between these assemblies are within the normal range. If any of these voltages is outside the normal range, refer to the flowcharts to further troubleshoot the circuit associated with the abnormal voltage.

**Table 3-4. Voltage Measurements at J307 (A2 Interface to A1 Main board)**

<b>A1J307 Pin #</b>	<b>Signal Name</b>	<b>CV Mode Full Scale Voltage No Load</b>	<b>CC Mode Full Scale Voltage Full Load</b>
1	PM_INHIBIT (Enabled)	0	0
2	OV_SCR*	+5	+5
3	OV_PROG	+3.9	+3.9
4	FAN_PROG	+2.8	+3.8
5	OV_DETECT*	+5	+5
6	SW_POS (Norm)	+5	+5
7	RANGE_SELECT (High)	0	0
8	OS_TRIM_NEG (COMP)	+1.7	+1.7
	OS_TRIM_NEG (SCPI)	+4.0	+4.0
9	+5Vs	+5	+5
10	COMMON	0	0
11	COMMON	0	0
12	+15Vs	+15	+15
13	-15Vs	-15	-15
14	HS_THERM (@25C)	+2.5	+2.5
15	FUSE	+2.4	+2.6
16	IMON_H	0	+3.5
17	IMON_L	0	+14.7
	IMON_L (@20mA Out)	+4.8	+4.8
18	IMON_P	0	0
19	VMON	+4.8	+4.8
20	COMMON	0	0
21	COMMON	0	0
22	COMMON	0	0
23	COMMON	0	0
24	CV_PROG	-4.8	-4.8
25	CC_PROG	-4.8	-4.8
26	CC_DETECT*	+5	0
27	CCN_DETECT*	+5	+5
28	CV_DETECT*	0	+5

### 3 - Troubleshooting

#### Manual Fan Speed Control

Under some circumstances such as testing acoustical devices where the fan noise would interfere with the test, it would be advantageous to reduce the fan speed. If the test requires a very light load, the ambient temperature is low and the duration of the test is short, the fan speed may be temporarily reduced. The turn-on default is "Automatic" so this procedure must be performed, as needed, every time the line voltage is turned on. To manually control the fan speed:

- a. Simultaneously depress the "0" and "9" keys. EEINIT <model> will be displayed.
- b. Using the Up/Down annunciator keys select FAN:MODE<AUTO.>.
- c. Using the Up/Down arrows select FAN:MODE <MAN>
- d. Press "Enter"
- e. Simultaneously depress the "0" and "9" keys. EEINIT <model> will be displayed.
- f. Using the Up/Down annunciator keys select FAN:SPEED <data>
- g. Press "Enter Number".
- h. Enter the desired speed (numeric entry range is 0 to 100%)
- i. Press "Enter"

#### Disabling Protection Features

Except for overvoltage protection, the power supply's protection features may be disabled. This is not recommended as a normal operating condition but is helpful under some circumstances such as troubleshooting. The turn-on default is "NO-PROTECT OFF" (protection enabled) so this procedure must be performed, as needed, every time the line voltage is turned on. To disable the protection:

- a. Simultaneously depress the "0" and "9" keys. EEINIT <model> will be displayed.
- b. Using the Up/Down annunciator keys select NO-PROTECT <OFF>.
- c. Using the Up/Down arrows select NO-PROTECT <ON>.
- d. Press "Enter"



## Post-repair Calibration

Calibration is required annually and whenever certain components are replaced. If components in any of the circuits listed below are replaced, the supply must be re-calibrated as described in Appendix B of the User's Guide.

- a. A1 Control Board: Voltage or Current Monitor Amplifier circuits, High Bandwidth Current Amplifier, or Current Monitor resistors R403/R473
- b. A2 Interface Board

If the Interface board A2 is replaced, the supply must be initialized first (see "Initialization" later in this chapter) and then be calibrated.

### Inhibit Calibration Switch

If "CAL DENIED" appears on the display when calibration is attempted, or if error code 401 occurs when calibrating over the GPIB, the internal INHIBIT CAL switch has been set. This switch setting prevents unauthorized or inadvertent power supply calibration. You must reset this switch in order to calibrate the supply.

This four-section switch, S201, is located on the A2 Interface board near the GPIB connector. The switch has 2 functions related to calibration. One is Inhibit Calibration. With this switch set the supply will not respond to calibration commands, thus providing security against unauthorized calibration. The other switch allows you to bypass the password in case it is forgotten.

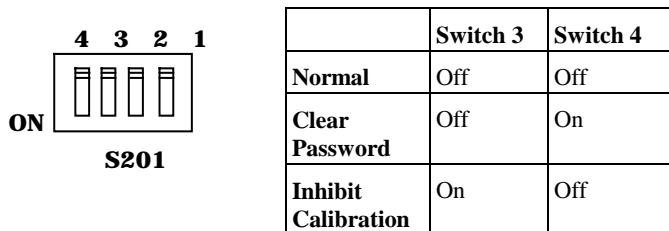

### Calibration Password

In order to enter the calibration mode, you must use the correct password as described in Appendix B of the Operating Manual. As shipped from the factory, the number 0 (zero) is the password. If you use an incorrect password, "OUT OF RANGE" will appear on the display for front panel calibration (or error code 402 occurs for GPIB calibration) and the calibration mode will not be enabled.

If you have changed the password and have forgotten it, you can set the configuration switch on A2 Interface board to bypass the password. See "Calibration Switch" paragraph above.

### Initialization

The dc power supply's GPIB address and model number as well as other constants which are required to program and calibrate the supply are stored in a EEPROM on the A2 Interface board. The Interface board also contains references and other components that will affect the alignment of the supply. If the Interface board is replaced, the supply must be reinitialized and calibrated. To initialize the power supply:

- a. Enable the Calibration mode
- b. Simultaneously depress the "0" and "9" keys.
- c. Using the Up/Down arrows select the appropriate model number
- d. Press "Enter"

The dc power supply will go through the turn-on self test sequence. It is now re-initialized and must be calibrated. See Appendix A of the User's Guide for the calibration procedure.

---

### ROM Upgrade

#### Identifying the Firmware

You can use the \*IDN? query to identify the revision of the supply's firmware. The query will readback the revisions of the Primary Interface ROM located on the A2 Interface board. The manufacturer and model number of the supply are also returned. The following is a sample program:

```
10 ALLOCATE L$[52]
20 OUTPUT 705; "*IDN?"
30 ENTER 705; L$
40 DISP L$
50 END
```

The computer will display the manufacturer's name, the model number, a "0," and then the firmware revision. Example: "AGILENT TECHNOLOGIES,66332A,0,A.00.01". The revision level of the ROM can also be found on the label affixed to the physical IC chip itself.

#### Upgrade Procedure

If the Interface board ROM is upgraded you can re-initialize the supply without affecting the calibration.

- a. Enable the Calibration mode.
- b. Simultaneously depress the "0" and "9" keys. EEINIT <model> will be displayed.
- c. Using the Up/Down annunciator keys select ROMUPD <model>.
- d. Using the Up/Down arrows select the appropriate model number.
- e. Press "Enter".

The supply will go through the turn-on self test sequence and return to the power supply metering mode.

## Disassembly Procedures

The following paragraphs provide instructions on how to disassemble various components of the dc power supply. Once disassembled, the components can be reassembled by performing the disassembly instructions in reverse order. Figure 3-2 shows the location of the major components of the unit.

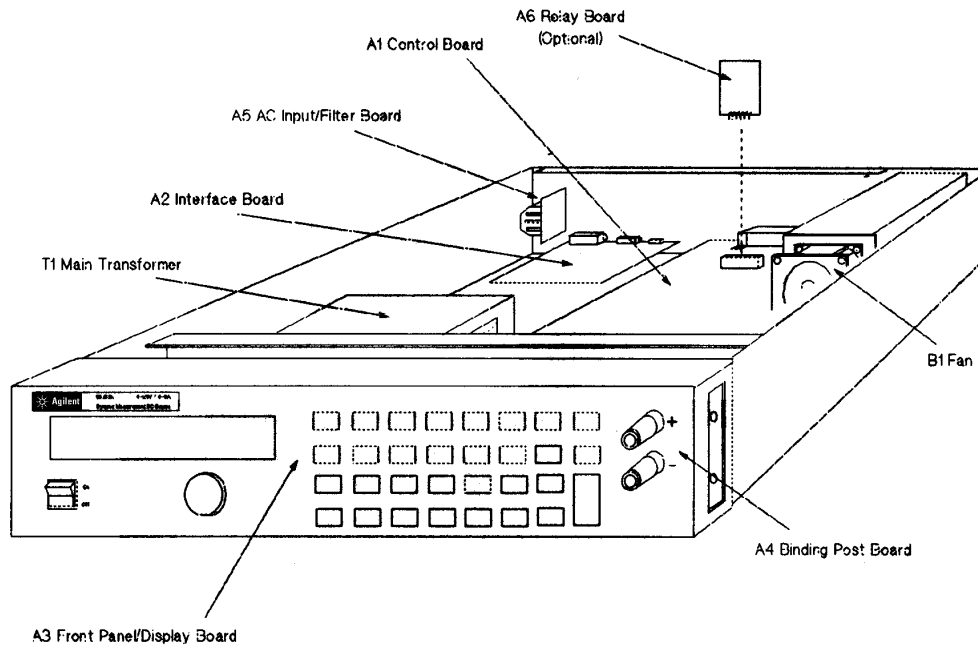

**Figure 3-2. Component Location**

---

**WARNING:**     **SHOCK HAZARD.** To avoid the possibility of personal injury, turn off AC power and disconnect the line cord before removing the top cover. Disconnect the GPIB cable and any loads, and remote sense leads before attempting disassembly.

---

**CAUTION:**     Most of the attaching hardware is metric. Use of other types of fasteners will damage threaded inserts. Refer to the list of required tools when performing disassembly and replacement.

---

### List of Required Tools

- a. 2PT Pozidriv screwdrivers.
- b. T10 and T15 Torx screwdrivers.
- c. Hex drivers: 7 mm for GPIB connector,  
3/16" for RS-232 connector,  
1/4" for front panel binding posts
- d. Long nose pliers.
- e. Antistatic wrist discharge strap.

### 3 - Troubleshooting

## Cover, Removal and Replacement

- a. Using a 2TP Pozi screwdriver, unscrew the two screws that hold the carrying straps to the power supply, and then remove the two screws from the opposite side of the case.
- b. To remove the cover, first spread the bottom rear of the cover slightly and push from the front panel
- c. Slide the cover backward until it clears the rear of the power supply.

## A2 Interface Board, Removal and Replacement

To remove the Interface Board, proceed as follows:

- a. Remove the cover of the power supply as described under, "Cover Removal and Replacement."
- b. Remove the two 7 mm and 3/16 inch hex screws that hold the GPIB and RS-232 connectors in place.
- c. Unplug the cable from J206. Depress the release button located at the end of the connector where the wires enter the housing.
- d. Unplug the flat cables. Note the position of the conductive side for reinstallation. Connectors release the cable by pulling out end tabs as shown by the arrows in the following figure.

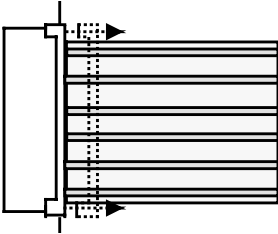

- e. Lift the board off of the snap-in standoffs.
- f. To reinstall the Interface board, perform the above steps in reverse order.

## Front Panel Assembly, Removal and Replacement

This procedure removes the front panel assembly from the dc power supply.

- a. Remove the Power Supply Cover as described earlier in, "Top Cover Removal and Replacement."
- b. Disconnect the cable between the Front Panel board and the Interface board at the Interface board.
- c. Carefully peel off the vinyl trim strips on each side of the front panel that cover the front panel screws.
- d. Using a Torx T10 driver remove the two screws (one on each side) that hold the front panel assembly to the chassis.
- e. Slide the Front Panel assembly forward and away from the chassis to access the S1 power switch.
- f. Disconnect the wires going to the S1 switch assembly. For reassembly, make a note of the color coding of the wires and the pins to which they are connected.
- g. If the supply has front panel binding posts, unplug the cable from the binding post connector and use a Torx T15 driver to remove the screw connecting the ground wire to the chassis.
- f. You can now remove the front panel assembly from the supply.
- g. To reinstall the Front Panel Assembly, perform the above steps in reverse order.

## S1 Line Switch, Removal and Replacement

- a. First remove the front panel assembly as described under “Front Panel Assembly, Removal and Replacement.”
- b. Release the switch from the front panel by pressing the locking tabs inward against the body of the switch and pushing the switch out of its opening.

---

**NOTE:** When reinstalling the switch, make sure that the letter “O” is facing up when the switch is installed in its opening.

---

## A3 Front Panel Board, Removal and Replacement

First remove the front panel assembly as described under, "Front Panel Assembly, Removal and Replacement." Once you have access to the front panel board perform these steps:

- a. Remove the RPG knob by pulling it away from the front panel.
- b. Use a Torx T10 driver to remove the screw that secures the board to the front panel assembly.
- c. Slide the board to the left to disengage the holding clips, then lift it out.
- d. To reinstall the Front Panel board, perform the above steps in reverse order.

## A1 Main Control Board

- a. Remove the top cover and the A2 Interface board as previously described.
- b. Disconnect all cables going to connectors on the main control board.

---

**NOTE:** Be sure to note the position and orientation of all cables prior to removal so that no mistake is made later when reinstalling these cables.

---

- c. If your power supply is equipped with a relay option board, remove the Torx T10 screw that holds the relay board bracket.
- d. Remove four Torx T15 screws that secure the main control board to the chassis.
- e. Slide the main board towards the front panel to release it from chassis mounted standoffs and then lift the board out of the chassis.

## T1 Power Transformer, Removal and Replacement

To remove the power transformer, the front panel assembly must first be removed to gain access to the bracket screws that hold the transformer in place.

- a. Remove the three Torx T10 screws securing the rear of the transformer bracket to the bottom of the chassis and the two Torx T10 screws securing the front of the transformer to the chassis.
- b. Use long nose pliers to disconnect all wires going to the transformer terminals.
- c. Lift the transformer out of the chassis.

---

**NOTE:** The AC power connections at the transformer primary are line voltage dependent. Refer to Figure 3-3 subsequent reconnection.

---

### 3 - Troubleshooting

## Line Voltage Wiring

Figure 3-3 illustrates the primary wiring configuration of the power transformer for various ac line voltages. Use long nose pliers to disconnect the wires going to the transformer terminals.

**NOTE:** Install the correct fuse when changing the ac line voltage from a previous setting:  
 for 110/120 Vac: 4 AM, Agilent p/n 2110-0055;  
 for 220/230 Vac: 2 AM, Agilent p/n 2110-0002

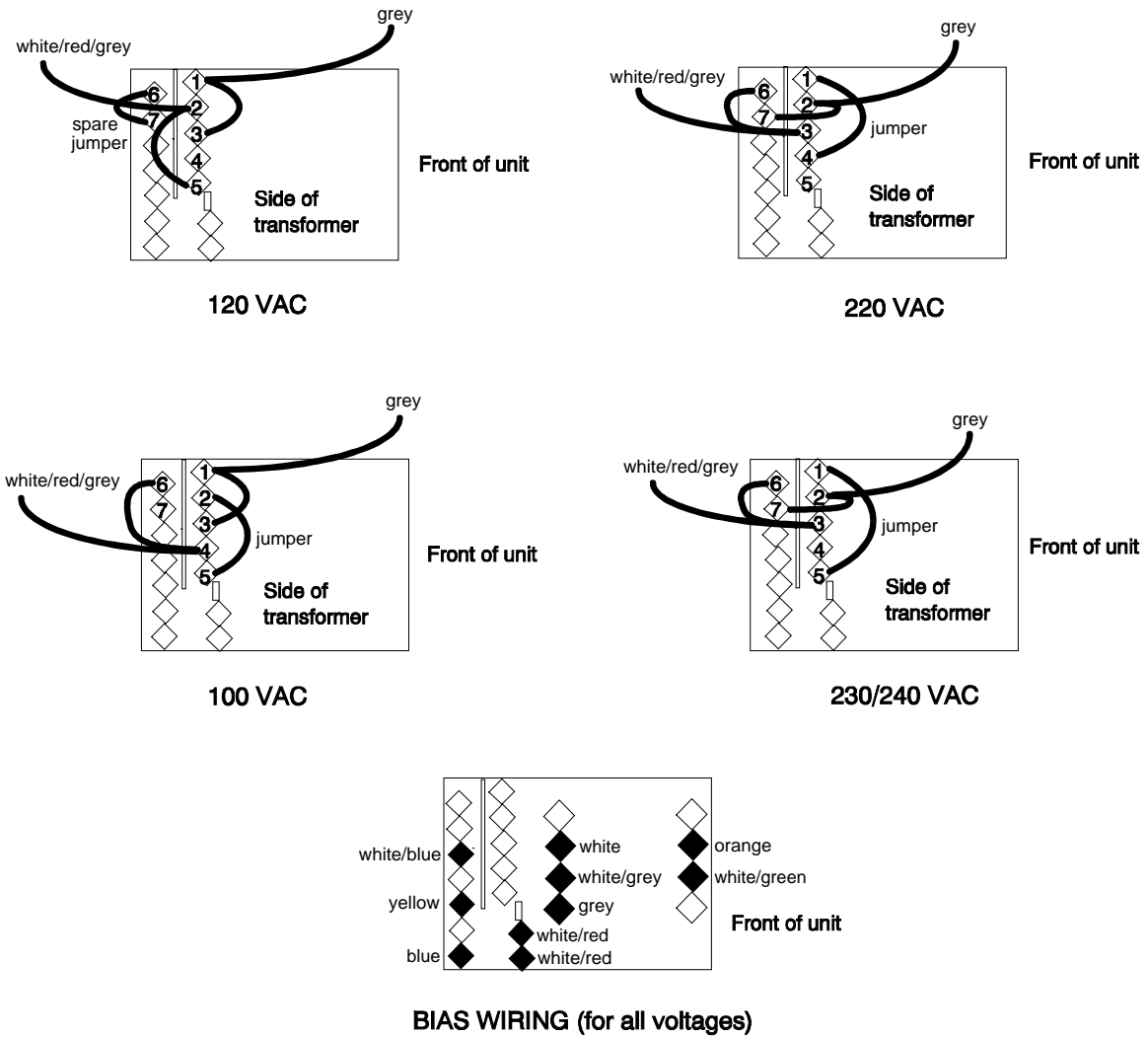

**Figure 3-3. Transformer Wiring**

## Principles of Operation

### Introduction

This section describes the different functional circuits used in the dc power supply models covered in this manual. First, the I/O external signals that connect to the Agilent power supply are described. Next, the overall block diagrams for the dc power supply are described in detail.

The simplified block diagrams in this section show the major circuits on the dc power supply as well as the signals between circuits. They also show the reference designations of some of the components in the functional circuit. These same reference designators are shown in the schematic diagrams in Section 6.

### I/O Interface Signals

Table 4-1 describes the interface signals between the power supply and the end user (or other external circuits and devices).

**Table 4-1. Power Supply Interface signals**

Connector	Signal	Description										
Front panel outputs	+OUT -OUT	Positive DC output voltage Negative DC voltage (or return)										
Rear panel output/sense screw terminals	+OUT -OUT + sense - sense common	Positive DC output voltage Negative DC voltage (or return) +OUT sensing terminal -OUT sensing terminal connected to ground conductor										
INH/FLT connector	pin 1 pin 2 pin 3 pin 4	<table border="0"> <tr> <td><u>FLT/INH mode</u><sup>1</sup></td> <td><u>Digital I/O mode</u></td> </tr> <tr> <td>FLT output</td> <td>OUT 0</td> </tr> <tr> <td>FLT Common</td> <td>OUT 1</td> </tr> <tr> <td>INH Input</td> <td>IN 2/OUT 2</td> </tr> <tr> <td>INH Common</td> <td>Common</td> </tr> </table> <sup>1</sup> as-shipped configuration	<u>FLT/INH mode</u> <sup>1</sup>	<u>Digital I/O mode</u>	FLT output	OUT 0	FLT Common	OUT 1	INH Input	IN 2/OUT 2	INH Common	Common
<u>FLT/INH mode</u> <sup>1</sup>	<u>Digital I/O mode</u>											
FLT output	OUT 0											
FLT Common	OUT 1											
INH Input	IN 2/OUT 2											
INH Common	Common											
RS-232 connector	XON-XOFF RTS-CTS DTR-DSR NONE	uses ASCII control codes DC# and DC1 uses Request-To-Send and Clear-To-Send lines uses Data-Terminal-Ready and Data-Set-Ready lines there is no flow control										
GPIB connector	GPIB/IEEE 488	Provides the interface to an external GPIB controller										
Ac input connector	ac mains	Can be 100 Vac, 120 Vac, 220 Vac or 240 Vac Input										

### **A3 Front Panel Circuits**

As shown in Figure 4-1, the supply's front panel assembly contains a circuit board, a keypad, a liquid crystal display (LCD), and a rotary control (RPG) for the output voltage and current. With the exception of the RPG (A3G1), the A3 Front Panel board is an assembly-level replaceable part. A separate front panel binding post board is also included on the unit. It is also available as an assembly-level replaceable part.

The A3 front panel board contains microprocessor circuits, which decode and execute all keypad and RPG commands that are transferred to the power supply output via the serial I/O port to the primary interface circuits on the A2 interface board. The front panel microprocessor circuits also process power supply measurement and status data received on the serial I/O port. This data is displayed on the LCD.

---

### **A2 Interface Circuits**

The circuits on the A2 interface board provide the interface between the GPIB interface, RS-232 interface, and front panel interface and the dc power supply. Communication between the power supply and a GPIB controller is processed by the GPIB interface and the primary microprocessor circuits on the A2 board. The A2 Interface board is assembly-level replaceable; it contains no user-replaceable parts.

With the exception of the front panel microprocessor, all digital circuits, analog-to-digital converters (ADC) and digital-to-analog converters (DAC) in the dc power supply are located on the A2 Interface board. All control signals between the A2 interface board and the A1 main board are either analog or level signals.

#### **Primary Interface**

The primary microprocessor circuits (DSP, ROM, and RAM chips) decode and execute all instructions and control all data transfers between the controller and the secondary interface. The primary microprocessor circuits also processes measurement and status data received from the secondary interface.

A Dual Asynchronous Control chip on the A2 board converts the RS-232, RI/DFI, and front panel data into the primary microprocessor's 8-bit data format. The serial data is transferred between the primary interface and the secondary interface via a serial bus and optical isolator chips. These chips isolate the primary interface circuits (referenced to earth ground) from the secondary interface circuits.

#### **Secondary Interface**

The secondary interface circuits include a programmed logic array, EEPROM, boot-ROM, 8 and 12-bit DAC circuits, and 8 and 16-bit ADC circuits. The programmed logic array translates the serial data received from the primary interface into a corresponding digital signal for the appropriate DAC/ADC circuits. The logic array is also connected directly to four DAC/ADC circuits. Under control of the logic array, the selected DAC converts the data on the bus into an analog signal. Conversely, the selected ADC converts the analog signals from the A1 board into a digital signal.

The logic array also directly receives status information from the A1 main board via three level-sensitive signal lines, which inform the array of the following operating conditions: constant voltage mode (CV\_Detect\*), constant current mode (CC\_Detect\*), negative current mode (CCN\_Detect\*), and overvoltage (OV\_Detect\*). The PM\_Inhibit control signal is used to shut down the bias voltage to the output stages and keep the power supply output off. The OV\_SCR\* control signal is used to fire the SCR and keep the power supply output off when an overvoltage condition has occurred.



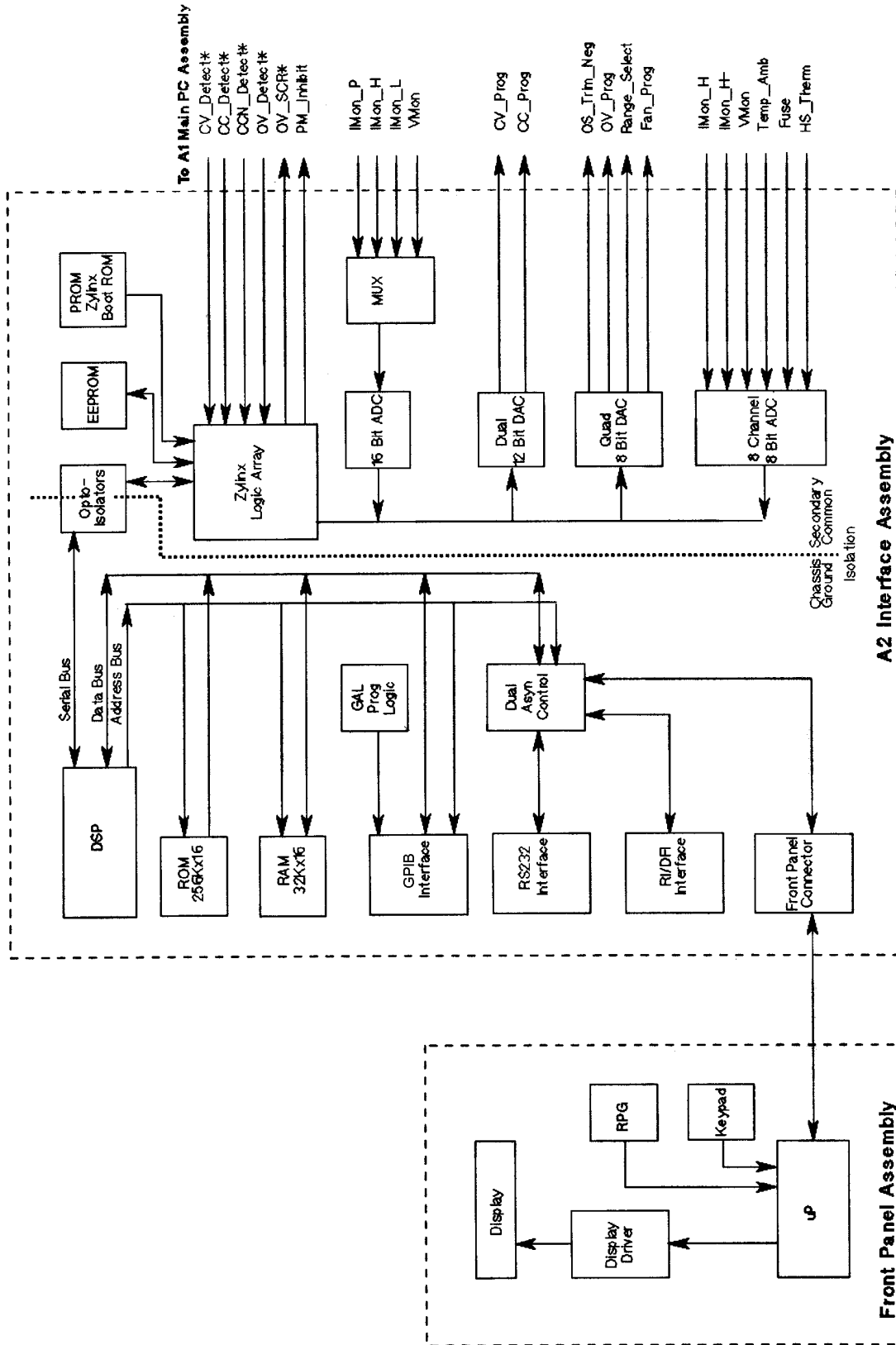

Figure 4-1. A2/A3 Block Diagram

## 4 - Principles of Operation

The EEPROM (electrically erasable programmable read-only memory) chip on the A2 interface board stores a variety of data and configuration information. This information includes calibration constants, GPIB address, present programming language, and model-dependent data, such as the minimum and maximum values of voltage and current. One of the EEPROM storage locations holds a checksum value which is used to verify the integrity of the EEPROM data. Access to the calibration data in the EEPROM is controlled by the combination of a password and switch settings on A2S201, located on A2 interface board (See Chapter 3 "Inhibit Calibration Switch").

The Dual 12-bit DAC converts the programmed value of voltage and current on the bus into the CV\_Prog and CC\_Prog signals, which are sent to the CV control circuits in order to control the magnitude of the output voltage in the CV mode and output current in CC mode. The CV\_Prog and CC\_Prog signals are in the 0 to -5 V range, which corresponds to the zero to full-scale output ratings of the dc power supply.

The Quad 8-bit DAC converts programmed information for the following circuits into analog format: negative offset trim (OS\_Trim\_Neg), overvoltage setting (OV\_Prog), current measurement range select (Range\_Select), and fan speed programming (Fan\_Prog). The OS\_Trim\_Neg signal allows the negative current control circuit to be calibrated at zero. The OV\_Prog signal is applied to the OV detect circuit, which compares the programmed overvoltage setting with the actual output voltage. The Range\_Select signal selects either the high or the low (20mA) measurement range. The Fan\_Prog signal is applied to the fan speed control circuit in order to speed up the fan as temperature increases, and to slow the fan speed down as temperature decreases.

The 16-bit ADC in conjunction with a 4x1 multiplexer returns data from the following measurement signals to the logic array: monitored output voltage (VMon), monitored high-range current (Imon\_H), monitored low-range current (Imon\_L), and monitored peak current (Imon\_P). All measurement signals are in the range of 0 to +5V, which corresponds to the zero to full-scale readback capability of the dc power supply.

The 8-channel, 8-bit ADC returns the following signals to the logic array: high-range output current (Imon\_H), high range negative current (Imon\_H-), overvoltage (V\_Mon), ambient temperature (Temp\_Amb), heatsink temperature (HS\_Therm), and output fuse state (Fuse). Five of these signals are for fan control. The logic array varies the Fan\_Prog signal depending upon the ambient temperature, the heatsink temperature, and the present output voltage and current. The Fuse signal informs the logic array if the output fuse (F300) is open.

---

## A1 Main Board Circuits

### Power Circuits

As shown in Figure 4-2, the power circuits consist of: input power rectifiers and filter, current-monitoring resistors, an output stage, a voltage gain stage, an overvoltage SCR, and an output filter.

The ac input rectifier and filter converts ac input to a dc level. The output stage regulates this dc level at the output of the power supply. The output stage has up to four parallel NPN transistors mounted on a heatsink and connected between the +Rail and the +Output. These transistors are driven to conduct by a positive-going signal from driver Q303 (located in the voltage gain stage). The output stage also has up to four parallel PNP transistors mounted on a heatsink and connected between the +Rail and the -Rail. These transistors are driven to conduct by a negative-going signal from driver Q304 (located in the voltage gain stage).

The voltage gain stage is controlled by a signal from the control circuits. A positive-going signal to the voltage gain stage makes the output more positive. A negative-going signal to the voltage gain stage makes the output more negative. The Turn-on control signal to the voltage gain stage simply keeps the output of the unit turned off for about 100 milliseconds at power turn-on while the microprocessor is initializing the unit.

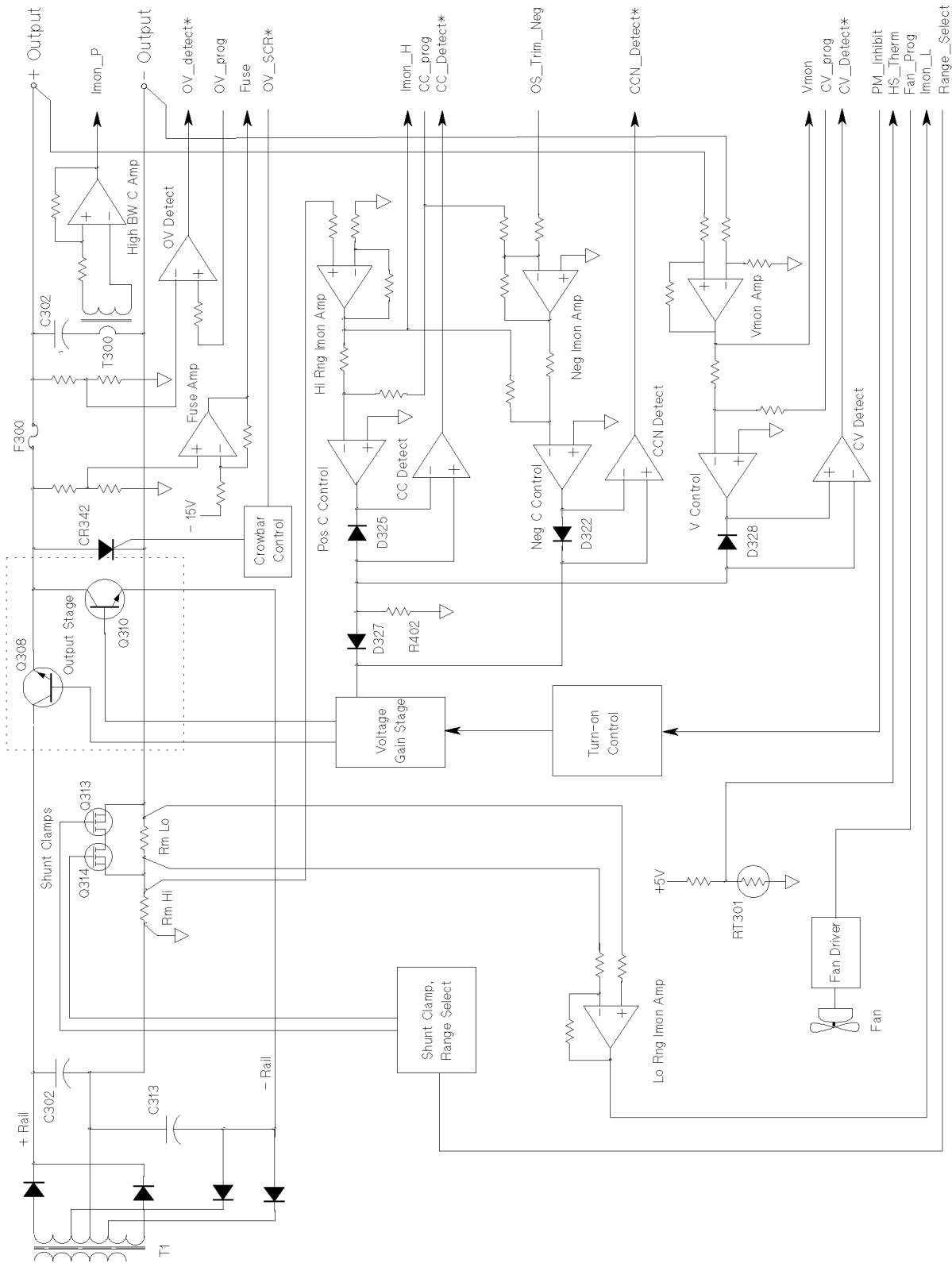

Figure 4-2. A1 Block Diagram

## 4 - Principles of Operation

Two current shunt resistors monitor the output current. RmHi (R473) monitors the high current range; RmLo (R403) monitors the low current range. Shunt clamps, connected in parallel across RmLo, turn on at approximately 25 mA to limit the voltage drop at high currents. The Range\_Select signal sets the level at which switching occurs. The output of the current monitor drives the level.

The SCR, connected across the output, will fire and short the output when an overvoltage condition is detected. The SCR is controlled by the OV\_SCR\* signal from the crowbar control circuit (described in the next section).

The output filter capacitor provides additional filtering of the dc output.

### Control Circuits

As shown in Figure 4-2, the control circuits consist of the CV/CC controls, output voltage/current monitor, bias supplies, and SCR control.

The CV/CC control circuits provide a CV control loop, a positive CC control loop, and a negative CC control loop. For any value of load resistance, the supply must act either as a constant voltage (CV) or as a constant current (CC) supply. Transfer between these modes is accomplished automatically by the CV/CC control circuit at a value of load resistance equal to the ratio of the programmed voltage value to the programmed current value. The negative CC control circuit is activated when a current source such as another power supply is connected across the output terminals and its voltage is greater than the programmed voltage. A low level CV\_Detect\*, CC\_Detect\*, or CCN\_Detect\* signal is returned to the secondary interface to indicate that the corresponding mode is in effect.

When the CV loop is in control, diode D328 is conducting current. Voltage regulation is accomplished by comparing the programmed voltage signal CV\_Prog with the output voltage monitor signal Vmon. The Vmon signal is in the 0 to +5 V range, which corresponds to the zero to full-scale output voltage range of the supply. If the output voltage exceeds the programmed voltage, Vmon goes high and produces a more negative-going CV signal, which reduces the input to the voltage gain stage and lowers the output voltage. Conversely, if the output voltage is less than the programmed voltage, Vmon goes low and produces a more positive-going CV signal, which increases the input to the voltage gain stage and raises the output voltage. Depending upon the position of the sense switch, the output voltage is either monitored at the supply's output terminals (local), or at the load (remote) using the +S and -S terminals with remote sense leads connected to the load. If the output voltage goes higher than the programmed value, the unit starts sinking current to reduce the output voltage.

When the CC loop is in control, diode D325 is conducting current. Current regulation is accomplished by comparing the programmed current signal CC\_Prog with the output current monitor signal Imon\_H. The Imon\_H signal is produced by measuring the voltage drop across the current monitoring resistor and is in the 0 to +5 V range, which corresponds to the zero to full-scale output current range of the supply. If the output current exceeds the programmed current, Imon\_H goes high and produces a more negative going CC signal, which reduces the input to the voltage gain stage and lowers the output current. Conversely, if the output current is less than the programmed current, Imon\_H goes low and produces a more positive-going CC signal, which increases the input to the voltage gain stage and raises the output current.

When the supply is sinking current, only the CV control circuit or the CCN control circuit can be active. In this case, the supply is acting as a load instead of a power source and will attempt to pull the output voltage down by drawing off current from the externally applied source. The current that will be drawn from the externally supplied source is determined by the CC\_Prog signal. When the current required to reduce the voltage is less than the programmed current value, the CV control circuit is active and regulates the output voltage. When the current required to reduce the voltage exceeds the programmed current value, the CCN control circuit is active. It regulates the output current by comparing the negative Imon\_H signal to the inverted CC\_Prog signal.

During operation, a PM\_Inhibit signal will cause the turn-on control to turn off the bias to the voltage gain stage and shut down the output if any of the following occur:

The output is programmed off.

An overvoltage condition is detected (OV\_Detect\* signal is received).

The line voltage falls below 90 volts (approximately).

Current readback is provided by three separate circuits. The previously discussed high range current signal (Imon\_H) returns the high range current measurement. When the unit is operating in the low current readback mode, a separate low range current shunt and amplifier provides low-current readback via the Imon\_L signal. The Range\_Select signal drives shunt clamps Q304 and Q305, which clamp the voltage across RmLo to approximately 1.8 V. A third current readback circuit is available on the Agilent 66332A unit. It consists of a high bandwidth current amplifier that returns dynamic current measurements from the output filter capacitor via the Imon\_P signal. Note that the Imon\_H and the Imon\_P signal are combined to return the actual output current measurement.

An overvoltage detect circuit compares the output voltage to the programmed overvoltage setting. When the output exceeds the programmed setting, the OV\_Detect\* signal goes low, which informs the logic array that an OV condition has occurred. The crowbar control circuit is enabled when the OV\_SCR\* signal is received. When an overvoltage condition occurs, the SCR control circuit generates the OV signal, which causes the following actions to occur:

1. The SCR fires, shorting the supply's output.
2. The microprocessor circuits are notified of the OV condition (OV\_Detect\* is low) in order to program the output off, turn off the gain stage bias, and update the status of the unit.
3. When a output protection clear command is executed, the microprocessor circuits resets the OV circuits, turns on the gain stage bias, and programs the output to its previous level.

The fan driver control circuit provides the DC voltage to operate the cooling fan. The Fan\_Prog signal from the secondary interface circuit varies this voltage according to the ambient and heatsink temperature as well as the output voltage and current of the supply.



## Replaceable Parts List

### Introduction

This section lists the replaceable parts for Agilent Models 66332A, 6632B, 6633B, and 6634B power supplies. Refer to Figures 5-1 for the location of mechanical parts with the reference designators MP. Refer to the board location diagrams in Chapter 6 for the location of electrical parts.

**Table 5-1. Chassis, Electrical**

Designator	Model	Part_Number	Qty	Description
A1	66332A/6632B	5063-3431	1	Control PCA, Tested
A1	6633B	06633-61023	1	Control PCA, Tested
A1	6634B	06634-61023	1	Control PCA, Tested
A2	66332A	5063-3439	1	Interface PCA, Tested
A2	6632B/6633B/6634B	5063-3429	1	Interface PCA, Tested
A3	All	5063-3432	1	Front Panel PCA, Tested
A4	6633B/6634B	5063-3406	1	Binding Post PCA
A4	66332A/6632B	06611-60022	1	Binding Post PCA
A5	All	5063-3433	1	AC Input/RFI PCA
A6	All	5063-3434	1	Relay PCA, Tested
B1	All	06632-60002	1	Fan Assembly
T1	66332A/6632B	9100-5501	1	Main Transformer
T1	6633B	9100-5567	1	Main Transformer
T1	6634B	9100-5568	1	Main Transformer
S1	All	3101-2862	1	Rocker Switch (AC Line)
W1	All	06612-80001	1	Cable (A5 to S1)
W2	All	06612-80002	1	Cable (S1 to T1)
W3	All	06632-80004	1	Cable (T1 to A1J303)
W4	All	06612-80008	1	Cable (T1 to A1 J304/J305)
W5	All	06612-80003	1	T1 Jumper
W6	All	5080-2452	1	Cable (A1 to A2 J206)
W7	All	5080-2448	1	Cable (A1 to A2 J207)
W10	All	5080-2457	1	Cable (A2 J210 to A6 J610)
W11	All	5080-2457	1	Cable (A2 J211 to A3 J111)
W15	All	06612-80010	1	Cable (A1 J314 to A4 J615)
	All	8120-4383	1	Line Cord, Standard (Option 903)
	All	8120-1350	1	Line Cord, Option 900
	All	8120-1369	1	Line Cord, Option 901
	All	8120-1689	1	Line Cord, Option 902
	All	8120-0698	1	Line Cord, Option 904
	All	8120-2104	1	Line Cord, Option 906
	All	8120-2956	1	Line Cord, Option 912
	All	8120-4211	1	Line Cord, Option 917
	All	8120-4753	1	Line Cord, Option 918

## 5 - Replaceable Parts

**Table 5-2. Chassis, Mechanical**

Designator	Model	Part Number	Qty	Description
MP1	All	06612-00002	1	Chassis
MP2	All	5063-3426	1	Front Panel Assy, Std unit
MP2	All	5063-3443	1	Front Panel Assy, Option 020
MP3	All	0370-3238	1	Knob, 6mm
MP4	All	06612-40001	1	Keypad
MP5	All	1510-0091	2	Binding Post, Single, Red
MP6	66332A	66332-80001	1	Nameplate (66332A)
MP6	6632B	06632-80019	1	Nameplate (6632B)
MP6	6633B	06633-80002	1	Nameplate (6633B)
MP6	6634B	06634-80002	1	Nameplate (6634B)
MP7	All	5001-9847	1	Top Cover
MP8	All	5041-8819	1	Strap Handle Cap, front
MP9	All	5041-8820	1	Strap Handle Cap, rear
MP10	All	5062-3702	1	Strap Handle
MP11	All	06624-20007	1	Barrier Block Cover
MP12	All	1252-1488	1	Terminal Block, 4 Position, RI/DFI
MP13	All	06611-40006	1	Fan Spacer (G10)
MP14	All	5020-2859	1	Main Heat Sink
MP15	All	06612-20002	1	Thermal Insulator
MP16	All	0515-0433	15	Screw M4x0.7x8mm, Torx T15, Pan, Conical washer
MP17	All	1400-1826	8	Spring Clip
MP18	All	06612-20001	4	Insulator
MP19	All	06612-80004	1	Rear Label
MP20	All	5041-8801	4	Foot
MP21	All	0515-1117	2	Screw M5x0.8x10mm, Pozi, Flat, Patch Lock
MP22	All	0515-1132	2	Screw M5x0.8x10mm Pozi, Pan, Patch Lock
MP23	All	06612-00005	1	Relay Option Bracket
MP24	All	06612-00004	1	Binding Post Plate
MP25	All	2950-0144	2	Nut, Hex 3/8-32 Nylon
MP26	All	0590-0305	2	Nut, Hex w/Lockwasher 6-32
MP27	All	5001-0538	2	Side Trim
MP28	All	0380-0644	2	Stud Mounted Standoff
MP29	All	2190-0034	2	Washer, Helical Lock #10
MP30	All	3050-0849	2	Washer, Flat #10
MP31	All	5001-6788	1	Transformer Bracket
MP32	All	5001-6787	1	Transformer Shim
MP33	All	1400-1281	2	Cable Clip
MP34	All	0515-0380	10	Screw M4x0.7x10mm, Torx T15, Pan, conical washer
MP35	All	0515-1946	1	Screw M3x0.5x6mm, Torx T10, Flat, Patch Lock
MP36	All	0515-2535	4	Screw, M3x0.5x8mm, Torx T10, Thread Rolling
MP37	All	0515-0374	6	Screw M3x0.5x10mm, Torx T10, Pan, conical washer
MP38	All	0535-0031	2	Nut, Hex w/lockwasher, M3x0.5
MP39	All	0460-2362	1	Foam Pad
MP40	All	0380-2086	2	Standoff, snap-in
MP41	All	8160-0916	2	RFI Clip
MP42	All	1252-3056	2	Screw Lock Kit (ref RS232 Connector)
	All	5962-0872	1	Operating Guide
	All	5962-8108	1	Programming Guide



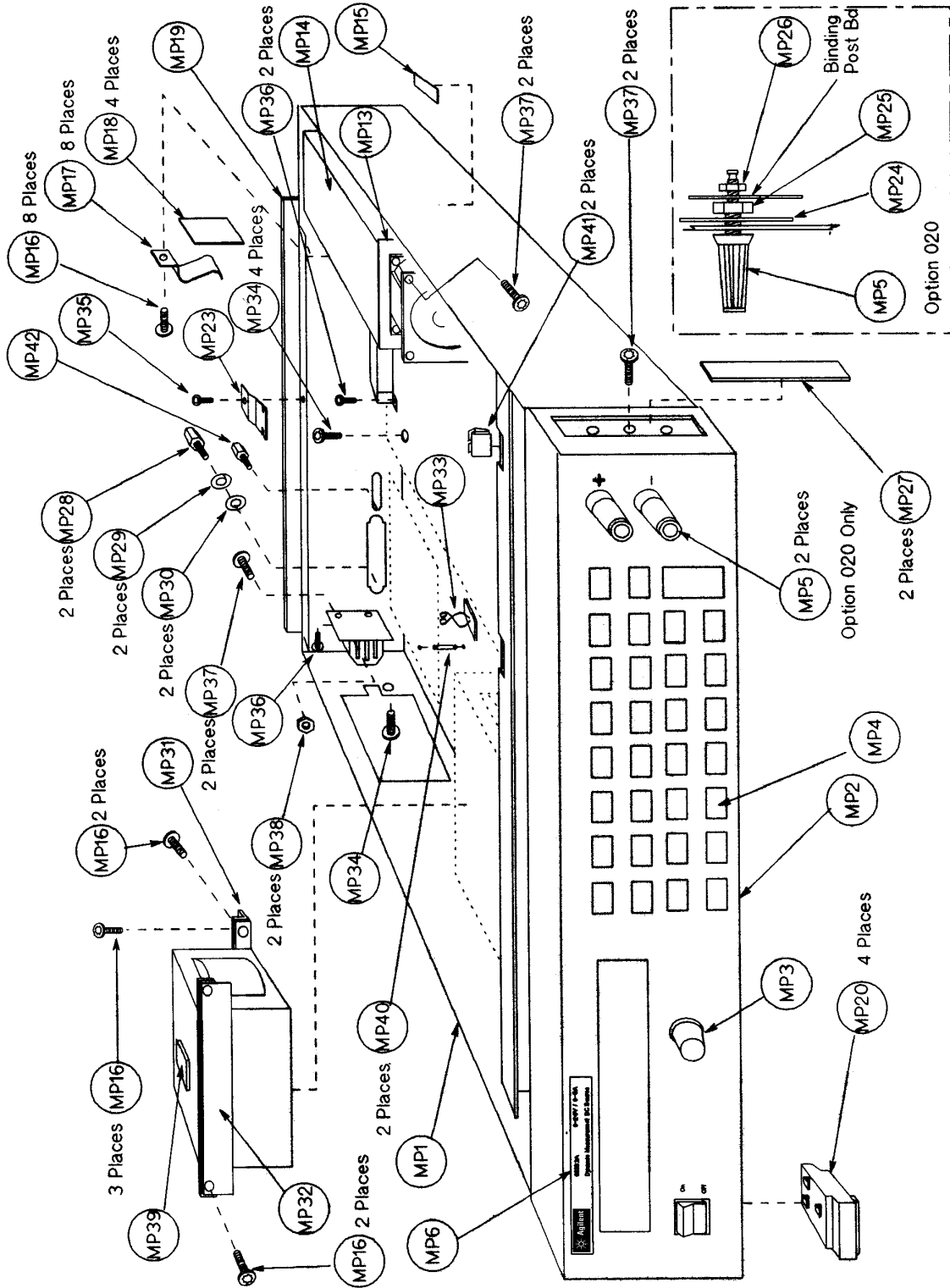

Figure 5-1. Mechanical Parts Identification

## 5 - Replaceable Parts

**Table 5-3. A1 Control Board PC Board Assembly**

<b>Designator</b>	<b>Model</b>	<b>Part Number</b>	<b>Qty</b>	<b>Description</b>
A1	66332A/6632B	5063-3431	1	Control PCA, Tested
A1	6633B	06633-61023	1	Control PCA, Tested
A1	6634B	06634-61023	1	Control PCA, Tested
C300	66332A/6632B	0160-5422	1	Cap 0.047 uF 20%
C301	All	0160-5422	1	Cap 0.047 uF 20%
C303	66332A/6632B	0180-4756	1	Cap 18,000 uF 50V
C303	6633B	0180-4815	1	Cap 2200 uF 160V
C303	6634B	0180-4816	1	Cap 1200 uF 250V
C304	66332A/6632B	0160-5422	1	Cap 0.047 uF 20%
C305	All	0180-2980	1	Cap 1000 uF 50V
C306	All	0180-4033	1	Cap 2200 uF 35 V
C307	66332A/6632B	0160-5422	1	Cap 0.047 uF 20%
C308, 309	All	0160-5422	2	Cap 0.047 uF 20%
C310	All	0180-4818	1	Cap 8200 uF 16V
C311, 312	All	0160-5422	2	Cap 0.047 uF 20%
C313	66332A/6632B	0180-4819	1	Cap 33,000 uF 25V
C313	6633B	0180-4817	1	Cap 18,000 uF 16V
C313	6634B	0180-4818	1	Cap 8200 uF 16V
C314	66332A/6632B	0160-5422	1	Cap 0.047 uF 20%
C315, 316	66332A/6632B	0160-5422	2	Cap 0.047 uF 20%
C317	All	0160-5422	1	Cap 0.047 uF 20%
C318, 319	All	0180-4129	2	Cap 1 uF 35V
C320	All	0180-4136	1	Cap 10 uF 20V
C321	All	0180-4129	1	Cap 1 uF 35V
C322	All	0160-5422	1	Cap 0.047 uF 20%
C323	All	0160-4831	1	Cap 4700 pF 10%
C324	All	0180-4129	1	Cap 1 uF 35V
C325 - 327	All	0160-5422	3	Cap 0.047 uF 20%
C328	All	0160-5098	1	Cap 0.22 uF 10%
C330	All	0160-4832	1	Cap 0.01 uF 10%
C331, 332	66332A/6632B	0160-4830	2	Cap 2200 pF 10%
C333	66332A/6632B	0160-5644	1	Cap 0.033 uF 10%
C334	66332A/6632B	0160-5422	1	Cap 0.047 uF 20%
C334	6633B/6634B	0160-4835	1	Cap 0.1 uF 10% 50V
C335	66332A/6632B	0160-7001	1	Cap 3300 pF 100V
C335	6633B	0160-5410	1	Cap 3300 pF
C335	6634B	0160-4834	1	Cap 0.047 uF 10%
C336	All	0160-4812	1	Cap 220 pF 5%
C337 - 339	All	0160-5422	3	Cap 0.047 uF 20%
C340	6634B	0160-6836	1	Cap 0.01 uF 250V
C341 - 343	All	0160-5422	3	Cap 0.047 uF 20%
C344	66332A/6632B	0160-5422	1	Cap 0.047 uF 20%
C344	6633B/6634B	0160-4833	1	Cap 0.022 uF
C345	All			Not loaded
C346	66332A/6632B	0160-5422	1	Cap 0.047 uF 20%
C346	6633B/6634B	0160-4833	1	Cap 0.022 uF
C347	All	0160-6827	1	Cap 0.022 uF 400V
C348	All	0160-5422	1	Cap 0.047 uF 20%

Replaceable Parts - 5

Designator	Model	Part Number	Qty	Description
C349	66332A/6632B	0160-4791	1	Cap 10 pF 5% 100V
C349	6633B/6634B	0160-4807	1	Cap 0.033 uF
C350	All	0160-5422	1	Cap 0.047 uF 20%
C351	All	0160-4791	1	Cap 10 pF 5% 100V
C352	66332A/6632B	0160-4791	1	Cap 10 pF 5% 100V
C352	6633B/6634B	0160-4807	1	Cap 0.033 uF
C353, 354	All	0160-5422	2	Cap 0.047 uF 20%
C355	66332A/6632B	0160-5422	1	Cap 0.047 uF 20%
C355	6633B/6634B	0160-4835	1	Cap 0.1 uF 10% 50V
C356	All			Not loaded
C357	All	0160-4801	1	Cap 100 pF 5%
C358	All	0160-4791	1	Cap 10 pF 5% 100V
C359	66332A/6632B	0160-4791	1	Cap 10 pF 5% 100V
C359	6633B/6634B	0160-4787	1	Cap 22 pF 5% 100V
C360	66332A/6632B	0160-4791	1	Cap 10 pF 5% 100V
C360	6633B	0160-4789	1	Cap 15 pF 5% 100V
C360	6634B	0160-4791	1	Cap 10 pF 5% 100V
C361	66332A/6632B	0160-4807	1	Cap 33 pF 5% 100V
C362	66332A/6632B	0160-4813	1	Cap 180 pF 5%
C362	6633B	0160-4812	1	Cap 220 pF 5% 100V
C362	6634B	0160-4800	1	Cap 120 pF 5%
C363	All	0160-4807	1	Cap 33 pF 5% 100V
C364	All	0160-5422	1	Cap 0.047 uF 20%
C365	All	0160-5471	1	Cap 0.1 uF 5% 50V
C366, 367	All	0160-4791	2	Cap 10 pF 5% 100V
C368	All	0160-4789	1	Cap 15 pF 5% 100V
C369	All	0160-6827	1	Cap 0.022 uF 400V
C370	All	0160-5422	1	Cap 0.047 uF 20%
C371	All	0160-4812	1	Cap 220 pF 5%
C372, 373	66332A/6632B	0160-5422	2	Cap 0.047 uF 20%
C374	All	0160-5422	1	Cap 0.047 uF 20%
C375	66332A/6632B/6633B	0160-5410	1	Cap 3300 pF 5%
C375	6634B	0160-5422	1	Cap 0.047 uF 20%
C376	66332A/6632B	0160-5422	1	Cap 0.047 uF 20%
C376	6633B	0160-4918	1	Cap 0.022 uF 20%
C376	6634B	0160-6616	1	Cap 6800 pF 20%
C377	66332A/6632B	0160-5422	1	Cap 0.047 uF 20%
C377	6633B	0160-4918	1	Cap 0.022 uF 20%
C377	6634B	0160-6616	1	Cap 6800 pF 20%
C378	66332A/6632B	0160-5422	1	Cap 0.047 uF 20%
C379	All	0160-8153	1	Cap 4700 pF
C380	All	0180-4129	1	Cap 1 uF 35V
C381	All	0160-8153	1	Cap 4700 pF
C382	66332A/6632B	0160-8231	1	Cap-MET 100 uF
C382	6633B	0160-8299	1	Cap 50 uF 70V
C382	6634B	0160-8230	1	Cap 22 uF 150V
C383	66332A/6632B	0160-5469	1	Cap 1 uF 10% 50V
C384	All	0160-4789	1	Cap 15 pF 5% 100V
C386	All	0160-4787	1	Cap 22 pF 5% 100V

## 5 - Replaceable Parts

Designator	Model	Part Number	Qty	Description
C403	66332A/6632B	0160-4791	1	Cap 10 pF 5% 100V
C405	All	0160-3454	1	Cap 220 pF 1KV
C411	6633B/6634B	0160-7277	1	Cap 2.2 uF
C420	6633B/6634B	0160-6800	1	Cap 0.022 uF 20%
C421	6633B/6634B	0160-6800	1	Cap 0.022 uF 20%
C422	6633B	0160-6180	1	Cap 1000 pF 20%
C422	6634B	0160-7336	1	Cap 220 pF 20%
C423	6633B	0160-6804	1	Cap 0.047 uF 20%
C423	6634B	0160-7568	1	Cap 0.0047 uF 10%
C424	6633B	0160-6180	1	Cap 1000 pF 20%
C424	6634B	0160-7336	1	Cap 220 pF 20%
C425	6633B/6634B	0160-4822	1	Cap 1000 pF
C426	6634B	0160-6806	1	Cap 0.1 uF
C427	6634B	0160-0157	1	Cap 4700 pF
C428 - 430	6633B/6634B	0160-6803	3	Cap 0.047 uF 250v 20%
C431, 432	6633B	0160-5847	2	Cap 0.22 uF
C480, 481	All	0160-5422	2	Cap 0.047 uF 20%
C482	6633B/6634B	0160-6800	1	Cap 0.022 uF 20%
C496, 497	All	0180-4129	2	Cap 1 uF 35V
C498	All	0160-4801	1	Cap 100 pF 5%
C499	66332A/6632B	0160-7562	1	Cap 6.8 uF 63 V
CR342	66332A/6632B	5060-3234	1	SCR/Rectifier Assembly (CR342/D330)
		1205-0571	1	ref CR342 Heat Sink
		1884-0310	1	ref CR342 SCR MCR69-3
		1901-0987	1	ref CR342 Power Diode D330
CR342	6633B	5060-3234	1	SCR/Rectifier Assembly (CR342/D330)
		1205-0571	1	ref CR342 Heat Sink
		1884-0310	1	ref CR342 SCR MCR69-3
		1901-0987	1	ref CR342 Power Diode D330
CR342	6634B	5060-3251	1	SCR/Heatsink Assembly
		1884-0316	1	ref CR342 SCR 2N6402
		1205-0571	1	ref CR342 Heat Sink
D300 - 303	All	1901-0731	4	Diode
D304	All	1901-1098	1	Diode
D305, 306	All	1901-0731	2	Diode
D307	All	1901-1098	1	Diode
D308	66332A/6632B	5060-3378	1	Rectifier Assembly
		1901-1383	1	ref D308 Power Diode
		1205-0282	1	ref D308 Heat Sink
D308	6633B/6634B	1901-1130	1	Diode
D309	66332A/6632B	5060-3228	1	Rectifier Assembly
		1901-0987	1	ref D309 Rectifier
		1205-0282	1	ref D309 Heat Sink
D309	6633B/6634B	1901-1130	1	Diode
D310	66332A/6632B	5060-3228	1	Rectifier Assembly
		1901-0987	1	ref D310 Rectifier
		1205-0282	1	ref D310 Heat Sink

Replaceable Parts - 5

Designator	Model	Part Number	Qty	Description
D310	6633B/6634B	1901-1130	1	Diode
D311	66332A/6632B	5060-3378	2	Rectifier Assembly
		1205-0282	1	ref D311 Heat Sink
		1901-1383	1	ref D311 Power Diode
D311	6633B/6634B	1901-1130	1	Diode
D312	All	1901-1098	1	Diode
D313, 314	All	1901-0731	2	Diode
D315	All	1901-0050	1	Diode
D316	All	1901-0719	1	Power Diode
D317	66332A/6632B	1901-1080	1	Diode
D317	6633B/6634B	1901-1098	1	Diode
D318	66332A/6632B	1901-1080	1	Diode
D318	6633B/6634B	1901-1098	1	Diode
D319 - 321	6633B/6634B	1901-1098	3	Diode
D322	All	1901-0050	1	Diode
D323, 324	All	1901-0033	2	Diode
D325	All	1901-0050	1	Diode
D326	All	1901-0033	1	Diode
D327, 328	All	1901-0050	2	Diode
D329	All	1901-0033	1	Diode
D330	66332A/6632B/6633B	1901-0987	1	Power Diode (See CR342)
D335	66332A/6632B	1902-0953	1	Zener Diode 6.2V 5%
D336, 337	All	1901-0880	2	Diode
D400	6634B	1901-0719	1	Diode, Power
D470, 471	All	1902-0960	2	Zener Diode 12V 5%
D499	66332A/6632B/6633B	1901-0987	1	Power Diode (See Q314)
F300, 301	All	2110-0712	2	Fuse, Submin 4AM, 125V
F302	66332A/6632B/6633B	2110-0697	1	Fuse, Submin 15AM, 32V
F302	6634B	2110-0685	1	Fuse, Submin 7AM, 125V
F303	66332A/6632B/6633B	2110-0697	1	Fuse, Submin 15AM, 32V
F303	6634B	2110-0685	1	Fuse, Submin 7AM, 125V
F304	All	2110-0699	1	Fuse, Submin 5AM, 125V
F305	66332A/6632B/6633B	2110-0777	1	Fuse 8AM 32V
F305	6634B	0811-3776	1	Res Fusible 0.5 Ohm 5W
	All	2110-1107	2	ref F305 Fuseholder Clips
F400, 406	66332A/6632B	Not Used	2	Replaced by track on all models
F401-405, 407	All	Not Used	6	Replaced by track on all models
J303	All	1252-0063	1	Connector
J304	All	1251-6832	1	Connector
J305	All	1252-0063	1	Connector
J307	All	1252-5977	1	Connector
J309	All	0360-2609	1	Barrier Block
J314	All	1252-0056	1	Connector
J414	All	1252-0063	1	Connector
J508	All	1252-3771	1	AC Line Module
L300, 301	66332A/6632B	9140-0115	2	Coil 22 uH 10%

## 5 - Replaceable Parts

Designator	Model	Part Number	Qty	Description
Q300	All	5060-3245	1	Darlington Fan Driver Assembly
	All	1854-0828	1	ref Q300 Transistor,NPN SI
	All	1205-0282	1	ref Q300 Heat Sink
Q301	66332A/6632B/6633B	1854-0474	1	Transistor, NPN
Q301	6634B	1854-0575	1	Transistor, NPN
Q302	66332A/6632B/6633B	1854-0474	1	Transistor, NPN
Q302	6634B	1854-0575	1	Transistor, NPN
Q303	66332A/6632B	06612-60008	1	Transistor Driver Assembly
		1854-0872	1	ref Q303 Transistor, NPN
		1205-0350	1	ref Q303 Heat Sink
Q303	6633B	06633-60009	1	Assembly, Transistor/Heat Sink
		1854-0920	1	ref Q303 Transistor, NPN
		1205-0571	1	ref Q303 Heat Sink
Q303	6634B	06634-60009	1	Transistor/HS Assembly
		1205-0571	1	ref Q303 Heat Sink
		1854-0838	1	ref Q303 Transistor, NPN
Q304	66332A/6632B	06612-60009	1	Transistor Driver Assembly
		1205-0350	1	ref Q304 Heat Sink
		1853-0497	1	ref Q304 Transistor, PNP
Q304	6633B	5063-3451	1	Assembly, Transistor/Heat Sink
		1853-0652	1	ref Q304 Transistor PNP Q304
		1205-0571	1	ref Q304 Heat Sink
Q304	6634B	5063-3451	1	Transistor/HS Assembly
		1853-0652	1	ref Q304 Transistor PNP Q304
		1205-0571	1	ref Q304 Heat Sink
Q305	All	1858-0054	1	Transistor Array
Q306	All	1853-0336	1	Transistor, PNP
Q307	All	1853-0086	1	Transistor, PNP
Q308	66332A/6632B	1854-1174	1	Transistor, NPN
Q308	6633B/6634B	1854-1362	1	Transistor, NPN
Q309	66332A/6632B	1854-1174	1	Transistor, NPN
Q309	6633B/6634B	1854-1362	1	Transistor, NPN
Q310	66332A/6632B	1853-0656	1	Transistor, PNP
Q310	6633B/6634B	1853-0772	1	Transistor, PNP
Q311	66332A/6632B	1853-0656	1	Transistor, PNP
Q311	6633B/6634B	1853-0772	1	Transistor, PNP
Q312	66332A/6632B	1854-1174	1	Transistor, NPN
Q313	All	06612-60006	1	FET Assembly
	All	1855-0831	1	ref Q313 MOSFET N-Chan
	All	1205-0350	1	ref Q313 Heat Sink
Q314	All	06612-60005	1	FET/Diode Assembly
	All	0590-0199	1	ref Q314 Hex Nut w/ Lockwasher
	All	1855-0726	1	ref Q314 MOSFET P-Chan
	All	1205-0350	1	ref Q314 Heat Sink
	All	0340-0950	1	ref Q314 Insulator
	All	2200-0143	1	ref Q314 Mach Screw 4-40
	All	1901-0987	1	ref Q314 Diode (D499)

Replaceable Parts - 5

Designator	Model	Part Number	Qty	Description
Q315	66332A/6632B	1854-1174	1	Transistor, NPN
Q315	6633B/6634B	1854-1362	1	Transistor, NPN
Q316	All	1855-1016	1	Transistor, FET
Q317	66332A/6632B	1853-0656	1	Transistor, PNP
Q317	6633B/6634B	1853-0772	1	Transistor, PNP
Q318	All	1858-0074	1	Transistor Array
Q319	66332A/6632B	1853-0656	1	Transistor, PNP
R300	66332A/6632B/6633B	0698-3642	1	Res 3K 5% 2W MO
R300	6634B	0764-0046	1	Res 33K 5% 2W MO
R301	66332A/6632B	0757-0403	1	Res 121 Ohm 1% 0.125W
R301	6633B	0757-0416	1	Res 511 1% 0.125W
R301	6634B	0757-0283	1	Res 2k 1% 0.125W
R302	66332A/6632B	0757-0403	1	Res 121 Ohm 1% 0.125W
R302	6633B	0757-0416	1	Res 511 1% 0.125W
R302	6634B	0757-0283	1	Res 2k 1% 0.125W
R303	All	0757-0280	1	Res 1K 1% 0.125W
R304	All	0698-3279	1	Res 4.99K 1%
R305	All	0698-4202	1	Res 8.87K 1%
R306	All	0757-0280	1	Res 1K 1% 0.125W
R307 - 309	All	0757-0442	3	Res 10K 1% 0.125W
R310	All	0698-3156	1	Res 14.7K 1%
R311	All	0686-2225	1	Res 2.2K 5% 0.5W
R312	All	0698-0092	1	Res 2.61K 1%
R313	66332A/6632B	0683-0475	1	Res 4.7 Ohm 5% 0.25W
R313	6633B/6634B	0757-0346	1	Res 10 1%
R314	All	0757-0442	1	Res 10K 1% 0.125W
R315	All	8159-0005	1	Jumper
R316	All	0757-0401	1	Res 100 Ohm 1% 0.125W
R317, 318	All	8159-0005	2	Jumper
R319	66332A/6632B	0698-3444	1	Res 316 Ohm 1% 0.125W
R319	6633B	0757-0416	1	Res 511 1%
R319	6634B	0757-0420	1	Res 750 1%
R320	66332A/6632B	0757-0427	1	Res 1.5K 1% 0.125W
R320	6633B	0698-0085	1	Res 2.61k 1%
R320	6634B	0757-0280	1	Res 1k 1%
R321	66332A/6632B	0698-4509	1	Res 80.6K 1%
R321	6633B	0698-3454	1	Res 215k 1%
R321	6634B	0698-4536	1	Res 340k 1%
R322	All	0757-0280	1	Res 1K 1% 0.125W
R323	66332A/6632B	0757-0280	1	Res 1K 1% 0.125W
R323	6633B	0757-0438	1	Res 5.11K 1%
R323	6634B	0698-3156	1	Res 14.7K 1%
R324	66332A/6632B	0757-0280	1	Res 1K 1% 0.125W
R324	6633B/6634B	0757-0438	1	Res 5.11K 1%
R325	66332A/6632B	0757-0280	1	Res 1K 1% 0.125W
R325	6633B	0698-3156	1	Res 14.7K 1%
R325	6634B	0757-0438	1	Res 5.11K 1%

## 5 - Replaceable Parts

Designator	Model	Part Number	Qty	Description
R326	66332A/6632B	0757-0200	1	Res 5.62K 1%
R326	6633B/6634B	0698-3159	1	Res 26.1K 1%
R327	All	0757-0280	1	Res 1K 1% 0.125W
R328	66332A/6632B	0683-0475	1	Res 20K 1% 0.125W
R328	6633B/6634B	0757-0346	1	Res 10 1%
R329	66332A/6632B	0757-0449	1	Res 4.7 Ohm 5% 0.25W
R329	6633B	0757-0453	1	Res 30.1K 1%
R329	6634B	0757-0458	1	Res 51.1K 1%
R330	66332A/6632B	0757-0280	1	Res 1K 1% 0.125W
R330	6633B/6634B	0698-3156	1	Res 14.7K 1%
R331	All	0757-0280	1	Res 1K 1% 0.125W
R332	All	0757-0199	1	Res 21.5K 1%
R333	66332A/6632B	0757-0438	1	Res 5.11K 1%
R333	6633B/6634B	0757-0441	1	Res 8.25K 1%
R334	66332A/6632B	8159-0005	1	Jumper
R335	All	0757-0438	1	Res 5.11K 1%
R336	All	0757-0280	1	Res 1K 1% 0.125W
R337	66332A/6632B/6633B	0698-3444	1	Res 316 Ohm 1% 0.125W
R337	6634B	0757-0420	1	Res 750 1% 0.125W
R339	66332A/6632B	0757-0442	1	Res 10K 1% 0.125W
R339	6633B	0757-0458	1	Res 51.1k 1% 0.125W
R339	6634B	0698-3454	1	Res 215K 1% 0.125W
R340	66332A/6632B	0757-0407	1	Res 200 Ohm 1% 0.125W
R340	6633B	0757-0414	1	Res 432 1% 0.125W
R340	6634B	0757-0280	1	Res 1K 1% 0.125W
R341	66332A/6632B	0698-3441	1	Res 215 Ohm 1%
R341	6633B	0757-0414	1	Res 432 1% 0.125W
R341	6634B	0757-0280	1	Res 1K 1% 0.125W
R342	66332A/6632B	0698-4509	1	Res 80.6K 1%
R342	6633B	0698-3456	1	Res 287K 1% 0.125W
R342	6634B	0698-3260	1	Res 464K 1% 0.125W
R343	66332A/6632B	0698-3441	1	Res 215 Ohm 1%
R343	6633B	0757-0414	1	Res 432 1% 0.125W
R343	6634B	0757-0280	1	Res 1K 1% 0.125W
R344	All	0757-0442	1	Res 10K 1% 0.125W
R345	All	0757-0280	1	Res 1K 1% 0.125W
R346	All	0757-0442	1	Res 10K 1% 0.125W
R347	All	0757-0458	1	Res 51.1K 1%
R348	66332A/6632B	0698-3444	1	Res 316 Ohm 1% 0.125W
R348	6633B	0698-4187	1	Res 632 1%
R348	6634B	0757-0427	1	Res 1.5K 1%
R349	66332A/6632B	0698-3159	1	Res 26.1K 1%
R349	6633B	0698-4509	1	Res 80.6K 1%
R349	6634B	0757-0468	1	Res 130K 1%
R350	66332A/6632B	0757-0279	1	Res 3.16K 1%
R350	6633B	0757-0435	1	Res 3.92K 1%
R350	6634B	0757-0279	1	Res 3.16K 1%



Replaceable Parts - 5

Designator	Model	Part Number	Qty	Description
R351	66332A/6632B	0698-6320	1	Res 5K 0.1%
R351	6633B	0698-5087	1	Res 6.2K 1%
R351	6634B	0698-6320	1	Res 5K 1%
R352	66332A/6632B	8159-0005	1	Jumper
R353	All	0698-8959	1	Res 619K 1%
R354	66332A/6632B	0757-0447	1	Res 16.2K 1%
R354	6633B	0757-0458	1	Res 51.1K 1%
R354	6634B	0698-4509	1	Res 80.6K 1%
R355	All	0698-0084	1	Res 2.15K 1%
R356	66332A/6632B	0757-0472	1	Res 200K 1%
R356	6633B	0757-0270	1	Res 249K 1%
R356	6634B	0757-0472	1	Res 200K 1%
R357	66332A/6632B	0699-2246	1	Res 25K 0.05%
R357	6633B/6634B	0699-1510	1	Res 22.22K 0.05%
R358	All			Not loaded
R359	66332A/6632B	8159-0005	1	Jumper
R360, 361	All	0699-2246	2	Res 25K 0.05%
R362	66332A/6632B	0698-8807	1	Res 39K 0.1%
R362	6633B/6634B	0699-1513	1	Res 40K 0.05%
R363	All	0757-0473	1	Res 221K 1%
R364	66332A/6632B	0699-2246	1	Res 25K 0.05%
R364	6633B/6634B	0699-1510	1	Res 22.22K 0.05%
R365, 366	All	0698-6392	2	Res 22K 0.1% 0.125W
R367	All	0757-0436	1	Res 4.32K 1%
R370	All	0757-0442	1	Res 10K 1% 0.125W
R371	66332A/6632B	0699-0934	1	Res 35.65K 0.1%
R371	6633B/6634B	0699-2246	1	Res 25K 0.05%
R372	66332A/6632B	0699-0236	1	Res 2.5K 0.1% 0.1W
R372	6633B/6634B	0699-1867	1	Res 3.2K 0.1% 0.1W
R373	66332A/6632B	0757-0401	1	Res 100 Ohm 1% 0.125W
R374	All	0757-0458	1	Res 51.1K 1%
R375	All			Not loaded
R376	66332A/6632B	0699-0934	1	Res 35.65K 0.1%
R376	6633B/6634B	0699-2246	1	Res 25K 0.05%
R377	66332A/6632B	0698-8807	1	Res 39K 0.1%
R377	6633B/6634B	0699-1513	1	Res 40K 0.05%
R378	66332A/6632B	0698-3634	1	Res 470 Ohm 5% 2W
R378	6633B/6634B	0698-3642	1	Res 3K 5% 2W MO
R379	All	0757-0436	1	Res 4.32K 1%
R380	All	0757-0401	1	Res 100 Ohm 1% 0.125W
R381	All	0698-8959	1	Res 619K 1% 0.125W
R382	All	0757-0401	1	Res 100 Ohm 1% 0.125W
R383	All	0698-3460	1	Res 422K 1%
R384	66332A/6632B	0811-1672	1	Res 3.3 Ohm 5% 2W
R384	6633B	0811-2553	1	Res 7.5 Ohm 5% 2W PW
R385	66332A/6632B	0699-0236	1	Res 2.5K 0.1% 0.1W
R385	6633B/6634B	0699-1867	1	Res 3.2K 1% 0.125W

## 5 - Replaceable Parts

Designator	Model	Part Number	Qty	Description
R386	66332A/6632B	0811-1672	1	Res 3.3 Ohm 5% 2W
R386	6633B/6634B	0811-2553	1	Res 7.5 Ohm 5% 2W PW
R387	66332A/6632B	0811-1672	1	Res 3.3 Ohm 5% 2W
R387	6633B/6634B	0811-2553	1	Res 7.5 Ohm 5% 2W PW
R388	All	0757-0442	1	Res 10K 1% 0.125W
R389	66332A/6632B	0811-1672	1	Res 3.3 Ohm 5% 2W
R389	6633B	0811-2553	1	Res 7.5 Ohm 5% 2W PW
R390, 391	All	0698-8834	2	Res 9K 0.1% 0.125W
R392	66332A/6632B	0698-6320	1	Res 5K 0.1%
R392	6633B/6634B	0698-6348	1	Res 3K 0.1% 0.125W
R393	66332A/6632B/6633B	0698-6360	1	Res 10K 0.1%
R393	6634B	0698-8865	1	Res 4.45K 0.1% 0.1W
R394	66332A/6632B	0698-6358	1	Res 100K 0.1%
R394	6633B	0698-6376	1	Res 200K 0.1% 0.1W
R394	6634B	0698-7841	1	Res 164K 0.1% 0.1W
R395, 396	All	0699-1866	2	Res 2.7K 0.1%
R397	6634B	0698-3642	1	Res 3K 2W
R398	All	0757-0442	1	Res 10K 1% 0.125W
R399	All	0698-6533	1	Res 12.5K 0.1%
R400, 401	All	0757-0442	2	Res 10K 1% 0.125W
R402	All	0757-0438	1	Res 5.11K 1%
R403	All	0699-4484	1	Res 72 Ohm
R404	66332A/6632B	0757-0442	1	Res 10K 1% 0.125W
R405	All	0698-8827	1	Res 1M 1% 0.125W
R406	All	0698-3456	1	Res 287K 1%
R407	66332A/6632B	0811-1672	1	Res 3.3 Ohm 5% 2W
R407	6633B	0811-2553	1	Res 7.5 Ohm 5% 2W PW
R408	66332A/6632B	0811-1672	1	Res 3.3 Ohm 5% 2W
R408	6633B/6634B	0811-2553	1	Res 7.5 Ohm 5% 2W PW
R409	66332A/6632B	0811-1672	1	Res 3.3 Ohm 5% 2W
R409	6633B/6634B	0811-2553	1	Res 7.5 Ohm 5% 2W PW
R410	66332A/6632B	0811-1672	1	Res 3.3 Ohm 5% 2W
R410	6633B	0811-2553	1	Res 7.5 5% 2W PW
R411	66332A/6632B/6633B	8159-0005	1	Jumper
R412	66332A/6632B/6633B	0698-3454	1	Res 215K 1%
R412	6634B	0698-3459	1	Res 383K 1%
R413	66332A/6632B	0757-0442	1	Res 10K 1% 0.125W
R414	All	0699-0088	1	Res 1.2M 1%
R415	66332A/6632B	0698-6392	1	Res 22K 0.1% 0.125W
R415	6633B/6634B	0699-1510	1	Res 22.22K 0.1%.125W
R416	All	0686-7515	1	Res 750 Ohm 5% 0.5W
R417	All	0757-0442	1	Res 10K 1% 0.125W
R418	66332A/6632B	0757-0458	1	Res 51.1K 1%
R418	6633B	0698-3201	1	Res 80K 1%
R418	6634B	0698-5092	1	Res 160K 1%
R419	All	0757-0442	1	Res 10K 1% 0.125W
R420	All	0699-1972	1	Res 1.74M 0.1% 0.125W

Replaceable Parts - 5

Designator	Model	Part Number	Qty	Description
R421	66332A/6632B	0811-1672	1	Res 3.3 Ohm 5% 2W
R421	6633B	0811-2553	1	Res 7.5 Ohm 5% 2W PW
R422	66332A/6632B	0698-6351	1	Res 133K 0.1%
R423	66332A/6632B/6633B	0699-0267	1	Res 10K 0.05%
R423	6634B	0699-0278	1	Res 15K 0.05% 0.1W
R425	66332A/6632B	0698-4539	1	Res 402K 1%
R427	66332A/6632B	0757-0442	1	Res 10K 1% 0.125W
R427	6633B/6634B	8159-0005	1	Jumper
R428	6634B	0698-3642	1	Res 3K
R429	66332A/6632B/6633B	0699-0267	1	Res 10K 0.05%
R429	6634B	0699-0278	1	Res 15K 0.05% 0.1W
R430	66332A/6632B	0757-0272	1	Res 52.3K 1%
R431	All	0757-0438	1	Res 5.11K 1%
R432	66332A/6632B	0757-0280	1	Res 1K 1% 0.125W
R432	6633B	0698-0084	1	Res 2.15K 1%
R432	6634B	0757-0438	1	Res 5.11K 1%
R433	66332A/6632B	0698-4099	1	Res 139 Ohm 1% 0.125W
R434	66332A/6632B	8159-0005	1	Jumper
R435	All	8159-0005	1	Jumper
R436, 437	66332A/6632B	0811-1672	2	Res 3.3 Ohm 5% 2W
R438	All	8159-0005	1	Jumper
R439	66332A/6632B	0698-6317	1	Res 500 Ohm 0.1%
R440	66332A/6632B	0811-1672	1	Res 3.3 Ohm 5% 2W
R440	6633B/6634B	0811-2553	1	Res 7.5 5% 2W PW
R441	All	0698-4486	1	Res 24.9K 1%
R442	66332A/6632B	0699-1513	1	Res 40K 0.05%
R442	6633B	0699-3416	1	Res 100K 0.05% 0.1W
R442	6634B	0699-3448	1	Res 300K 0.05% 0.1W
R443	66332A/6632B	0699-1513	1	Res 40K 0.05%
R443	6633B	0699-3416	1	Res 100K 0.05% 0.1W
R443	6634B	0699-3448	1	Res 300K 0.05% 0.1W
R444	All	0757-0438	1	Res 5.11K 1%
R445	66332A/6632B	0811-0929	1	Res 0.51 Ohm 5% 2W
R445	6633B	0812-0019	1	Res 0.33 5% 2W PW
R445	6634B	0811-1220	1	Res 1.5 5% 2W PW
R446	66332A/6632B	0698-6631	1	Res 2.5K 0.1%
R446	6633B	0698-8863	1	Res 5.2K 0.1%
R446	6634B	0699-0489	1	Res 16.1K 0.1%
R447	66332A/6632B	0698-4123	1	Res 499 Ohm 1% 0.125W
R448	All	8159-0005	1	Jumper
R449	66332A/6632B	8159-0005	1	Jumper
R450	66332A/6632B	0698-8812	1	Res 1 Ohm 1% 0.125W
R451	All	8159-0005	1	Jumper
R452	66332A/6632B	0757-0280	1	Res 1K 1% 0.125W
R452	6633B	0698-0084	1	Res 2.15K 1%
R452	6634B	0757-0438	1	Res 5.11K 1%
R453	66332A/6632B	0698-6360	1	Res 10K 0.1%
R454	All	8159-0005	1	Jumper

## 5 - Replaceable Parts

Designator	Model	Part Number	Qty	Description
R455	66332A/6632B	0698-6631	1	Res 2.5K 0.1%
R455	6633B	0698-8863	1	Res 5.2K 0.1%
R455	6634B	0699-0489	1	Res 16.1K 0.1%
R456	All	8159-0005	1	Jumper
R457	66332A/6632B	8159-0005	1	Jumper
R458	All	8159-0005	1	Jumper
R459	66332A/6632B	8159-0005	1	Jumper
R460	All	0698-6620	1	Res 150K 0.1%
R461	All	0757-0395	1	Res 56.2 Ohm 1%
R462	66332A/6632B/6633B	0757-0416	1	Res 511 Ohm 1% 0.125W
R462	6634B	0757-0394	1	Res 51.1 Ohm 1% 0.125W
R463	6634B	0698-3642	1	Res 3K 2W
R464, 465	All	0698-0084	2	Res 2.15K 1%
R466	66332A/6632B	0698-8812	1	Res 1 Ohm 1% 0.125W
R466	6633B	0683-0475	1	Res 4.7 Ohm
R466	6634B	0757-0379	1	Res 12.1 Ohm
R467, 468	66332A/6632B	0811-1672	2	Res 3.3 Ohm 5% 2W
R469	66332A/6632B	0811-1672	1	Res 3.3 Ohm 5% 2W
R469	6633B	0811-2553	1	Res 7.5 Ohm 5% 2W PW
R470	66332A/6632B	0811-1672	1	Res 3.3 Ohm 5% 2W
R470	6633B/6634B	0811-2553	1	Res 7.5 Ohm 5% 2W PW
R471	66332A/6632B	0699-1797	1	Res 10M 5% 0.25W
R471	6633B/6634B	0683-1065	1	Res 10M
R472	All	0757-0442	1	Res 10K 1% 0.125W
R473	66332A/6632B	0811-3770	1	Res 0.05 Ohm 1%
R473	6633B	0811-3771	1	Res 0.25 Ohm 1%
R473	6634B	0811-3772	1	Res 0.5 Ohm 1%
R474	All	8159-0005	1	Jumper
R476	All	0757-0281	1	Res 2.74K 1%
R477	All	0757-0199	1	Res 21.5K 1%
R478, 479	All	0698-4444	2	Res 4.87K 1%
R480, 481	All	0757-0269	2	Res 270 Ohm 1% 0.125W
R482	All	0698-3226	1	Res 6.49K 1%
R483	All	0698-5089	1	Res 33K 1% 0.125W
R488	66332A/6632B	0698-3922	1	Res 487K 0.1%
R488	6633B	0699-1744	1	Res 280K 0.1%
R488	6634B	0699-0070	1	Res 3.16M 1%
R489	66332A/6632B	0698-3922	1	Res 487K 0.1%
R489	6633B	0698-6950	1	Res 1.25M 0.1% 0.5W
R489	6634B	0699-0070	1	Res 3.16M 1%
R490	66332A/6632B	0699-0730	1	Res 1M 0.1%
R490	6633B	0699-0070	1	Res 3.16M 1%
R490	6634B	0683-6855	1	Res 6.8M 5%
R493	All	0757-0438	1	Res 5.11K 1%
R494, 495	All	0698-8812	2	Res 1 Ohm 1% 0.125W
R496	66332A/6632B	0757-0289	1	Res 13.3K 1%
R496	6633B/6634B	0757-0433	1	Res 3.32K 0.125W

## Replaceable Parts - 5

<b>Designator</b>	<b>Model</b>	<b>Part Number</b>	<b>Qty</b>	<b>Description</b>
R497	66332A/6632B	0757-0289	1	Res 13.3K 1%
R497	6633B/6634B	0757-0433	1	Res 3.32K 0.125W
R498 - 500	All	0757-0407	2	Res 200 Ohm 1% 0.125W
R505	6633B	Not Used	1	
R510 - 517	66332A/6632B	0811-1672	8	Res 3.3 Ohm 5% 2W
R520	6633B/6634B	Not Used	1	
R521	All	Not Used	1	Replaced by wire in 6633B/6634B units
R522	All	Not Used	1	
RT301	All	0837-0397	1	Thermistor
S300	All	3101-2927	1	Switch, Right Angle Slide
T300	66332A/6632B	9100-4350	1	Current Transformer
T300	6633B/6634B	8159-0005	1	Jumper
U300	All	5060-3229	1	-15V Regulator Assembly
	All	1826-0214	1	ref U300 Integrated Circuit
	All	1205-0282	1	ref U300 Heat Sink
U301	All	5063-2389	1	+5V Regulator Assembly (Interface Bias)
	All	1826-1597	1	ref U301 Integrated Circuit
	All	1205-0402	1	ref U301 Heat Sink
U302	All	5060-2948	1	+5V Regulator Assembly (Secondary Bias)
	All	1205-0282	1	ref U302 Heat Sink
	All	1826-0122	1	ref U302 Integrated Circuit
U303	All	1826-1533	1	Integrated Circuit
U304	All	5060-3232	1	+15V Regulator Assembly
	All	1826-0106	1	ref U304 Integrated Circuit
	All	1205-0282	1	ref U304 Heat Sink
U305	All	1826-0346	1	Integrated Circuit
U306	All	1826-1370	1	Integrated Circuit
U308	All	1826-1534	1	Integrated Circuit
U309	All	1826-3521	1	Integrated Circuit
U310	All	1826-2252	1	Integrated Circuit
U311	All	1826-3521	1	Integrated Circuit
U313	All	1826-1878	1	Integrated Circuit
U314	66332A/6632B	1826-3521	1	Integrated Circuit
U315	All	1826-1878	1	Integrated Circuit
U400	All	1826-0643	1	Integrated Circuit
VR300	All	1902-0955	1	Integrated Circuit
VR301	All	1902-0957	1	Zener Diode 9.1V 5%
VR302	6634B	1902-3092	1	Zener Diode 4.99V 5%
VR303	66332A/6632B	1902-0953	1	Zener Diode 6.2V 5%
VR303	6633B/6634B	1902-0958	1	Zener Diode 10V 5%
VR304	66332A/6632B	1902-0943	1	Zener Diode 2.4V 5%
VR304	6633B/6634B	1902-0947	1	Zener Diode 3.6V 5%
VR305	66332A/6632B	1902-0943	1	Zener Diode 2.4V 5%
VR305	6633B/6634B	1902-0947	1	Zener Diode 3.6V 5%
VR335	66332A/6632B	1902-0953	1	Zener Diode 6.2V 5%
VR335	6633B/6634B	1902-0957	1	Zener Diode 9.1V 5%
W300, 301	All	8159-0005	2	Jumper

## 5 - Replaceable Parts

<b>A2 Interface PCA, Tested for 66332A</b>	<b>5063-3439</b>	<b>No user replaceable parts</b>
<b>A2 Interface PCA, Tested for 6632B/6633B/6634B</b>	<b>5063-3429</b>	<b>No user replaceable parts</b>
<b>A3 Front Panel PCA Tested for all models</b>	<b>5063-3432</b>	<b>No user replaceable parts</b>

**Table 5-4. Binding Post Option #020**

<b>Designator</b>	<b>Model</b>	<b>Part Number</b>	<b>Qty</b>	<b>Description</b>
A4	6633B/6634B	5063-3406	1	Binding Post PCA
A4	66332A/6632B	06611-60022	1	Binding Post PCA
C603, 604	All	0160-8153	2	Cap 4700 pF
J615	All	1252-0056	1	4 Pin Connector
MP5	All	1510-0091	2	Binding Post, Single, Red
MP26	All	0590-0305	2	Nut, Hex 6-32 w/Lockwasher
MP25	All	2950-0144	2	Nut, Hex 3/8-32 Nylon
MP24	All	06612-00004	1	Binding Post Plate
W15	All	06612-80010	1	Cable (A1 J314 to A4 J615)

**Table 5-5. A5 AC input/RFI Board**

<b>Designator</b>	<b>Model</b>	<b>Part Number</b>	<b>Qty</b>	<b>Description</b>
A5	All	5063-3433	1	AC Input/RFI PCA
C500	All	0160-4259	1	Cap 0.22 uF 10%
C501, 502	All	0160-8181	2	Cap 0.0022 uF
F500	All	2110-0055	1	Fuse 4AM, 250V (100Vac and 120Vac input)
F500	All	2110-0002	1	Fuse 2AM, 250V (220Vac and 230Vac input)
J508	All	1252-3771	1	AC Line Module
XF500	All	2110-0927	1	Fuseholder, with cap

**Table 5-6. Relay Option #760**

<b>Designator</b>	<b>Model</b>	<b>Part Number</b>	<b>Qty</b>	<b>Description</b>
A6	All	5063-3434	1	Relay PCA, Tested
C600	All	0160-5422	1	Cap 0.047 uF 20%
C601, 602	All	0150-0081	2	Cap 0.01 uF
F601, 602	All	2110-0671	2	Fuse 0.125AM, 125V
J610	All	1252-7643	1	Connector
K601 - 603	All	0490-1405	3	Relay, 2C 12VDC
K604, 605	All	0490-1670	2	Power Relay
R601, 602	All	0686-2215	2	Res 220 Ohm 5% 0.5W
R603	All	0698-3439	1	Res 178 Ohm 1% 0.125W
R604	All	0757-0284	1	Res 150 Ohm 1% 0.125W
R605	All	0698-3439	1	Res 178 Ohm 1% 0.125W
R606	All	0757-0284	1	Res 150 Ohm 1% 0.125W
R607	All	0698-3439	1	Res 178 Ohm 1% 0.125W
U601	All	1858-0047	1	Transistor Array
W10	All	5080-2457	1	Cable (A2 J210 to A6 J610)

## Diagrams

### Introduction

This chapter contains drawings and diagrams for troubleshooting and maintaining the Agilent Model 66332A Dynamic Measurement DC Source and the Agilent Model 66332A/6632B/6633B/6634B System DC Power Supplies. Unless otherwise specified in the drawings, a drawing or diagram applies to all models and input voltage options.

### General Schematic Notes

- Components marked with an asterisk are model dependent (See Table 6-1).
- All resistors are in ohms 1%, 1/8 W, unless otherwise specified.
- All resistors are in ohms 1%, 1/8 W, unless otherwise specified.
- All capacitors are in microfarads unless otherwise specified.
- Unless otherwise noted, bias connections to integrated-circuit packages are as follows:

	<u>Common</u>	<u>5 V</u>
14-pin packages	pin 7	pin 14
16-pin packages	pin 8	pin 16
20-pin packages	pin 10	pin 20

**Table 6-1. Model-dependent Components**

Designator	66332A/ 6632B	6633B	6634B	Designator	66332A/ 6632B	6633B	6634B
C300, 304, 307	0.047 uF			C411		2.2 uF	2.2 uF
C302	18000 uF	2200 uF	1200 uF	C420, 421		0.022 uF	0.022 uF
C313	33,000 uF	18000 uF	8200 uF	C422, 424, 425		1000 pF	220 pF
C314-316	0.047 uF			C423		0.047 uF	0.0047 uF
C331, 332	2200 pF			C425		1000 pF	1000 pF
C333	0.033 uF			C426			0.1 uF
C335	3300 pF	3300 pF	0.047 pF	C427			4700 pF
C340			0.01 uF	C428-430		0.047 uF	0.047 uF
C344, 346	0.047 uF	0.022 uF	0.022 uF	C431, 432		0.22 uF	
C349, 352	10 pF	0.033 uF	0.033 uF	C482		0.022 uF	0.022 uF
C359	10 pF	22 pF	22 pF	C499	6.8 uF		
C360	10 pF	15 pF	10 pF	D319, 320, 321		Diode	Diode
C361	33 pF			D330	Diode	Diode	
C362	180 pF	220 pF	120 pF	D400			Diode
C372, 373	0.047 uF			D499	Diode	Diode	
C375			0.047 uF	F400, 406	0 Ohm		
C376, 377	0.047 uF	0.022 uF	6800 pF	L300, 301	22 uH		
C378	0.047 uF			Q312, 319	Transistor		
C382	100 uF	50 uF	22 uF	R300	3K	12K	33K
C383	1 uF			R301, 302	121 Ohm	511 Ohm	2k
C403	10 pF			R313	4.7 Ohm	10 Ohm	10 Ohm

6 - Diagrams

**Table 6-1. Model-dependent Components (continued)**

Designator	66332A/ 6632B	6633B	6634B	Designator	66332A/ 6632B	6633B	6634B
R319	316 Ohm	511 Ohm	750 Ohm	R413	10K		
R320	1.5K	2.61k	1k	R415	22K	22.22K	22.22K
R321	80.6K	215k	340k	R418	51.1K	80K	160K
R323	1K	5.11K	14.7K	R421	3.3 Ohm	7.5 Ohm	
R324	1K	5.11K	5.11K	R422	133K		
R325	1K	14.7K	5.11K	R423, 429	10K	10K	15K
R326	5.62K	26.1K	26.1K	R425	402K		
R328	20K	10 Ohm	10 Ohm	R427	10K	0 Ohm	0 Ohm
R329	4.7 Ohm	30.1K	51.1K	R428			3K
R330	1K	14.7K	14.7K	R430	52.3K		
R333	5.11K	8.25K	8.25K	R432	1K	2.15K	5.11K
R334	0 Ohm			R433	139 Ohm		
R337	316 Ohm	316 Ohm	750 Ohm	R434	0 Ohms		
R339	10K	51.1k	215K	R436, 437	0 Ohms		
R340	200 Ohm	432 Ohm	1K	R439	500 Ohm		
R341, 343	215 Ohm	432 Ohm	1K	R440	3.3 Ohm	7.5 Ohm	7.5 Ohm
R342	80.6K	287K	464K	R442, 443	40K	100K	300K
R348	316 Ohm	632 Ohm	1.5K	R445	0.51 Ohm	0.33	1.5
R349	26.1K	80.6K	130K	R446	2.5K	5.2K	16.1K
R350	3.16K	3.92K	3.16K	R447	499 Ohm		
R351	5K	6.2K	5K	R449	0 Ohm		
R352	0 Ohm			R450	1 Ohm		
R354	16.2K	51.1K	80.6K	R452	1K	2.15K	5.11K
R356	200K	249K	200K	R453	10K		
R357	25K	22.22K	22.22K	R455	2.5K	5.2K	16.1K
R359	0 Ohm			R457, 459	0 Ohm		
R362	39K	40K	40K	R462	511 Ohm	511 Ohm	51.1 Ohm
R364	25K	22.22K	22.22K	R463			3K
R371	35.65K	25K	25K	R466	1 Ohm	4.7 Ohm	12.1 Ohm
R372	2.5K	3.2K	3.2K	R467, 468	0 Ohm		
R373	100 Ohm			R469		7.5 Ohm	
R376	35.65K	25K	25K	R470		7.5 Ohm	7.5 Ohm
R377	39K	40K	40K	R473	0.05 Ohm	0.25 Ohm	0.5 Ohm
R378	470 Ohm	3K	3K	R488	487K	280K	3.16M
R384, 389	3.3 Ohm	7.5 Ohm		R489	487K	1.25M	3.16M
R385	2.5K	3.2K	3.2K	R490	1M	3.16M	6.8M
R386, 387	3.3 Ohm	7.5 Ohm	7.5 Ohm	R496, 497	13.3K	3.32K	3.32K
R392	5K	3K	3K	R505	1.25M		
R393	10K	10K	4.45K	R513, 515	0 Ohm		
R394	100K	200K	164K	R520		0 Ohm	0 Ohm
R397			3K	T300	Xfmr		
R404	10K			U314	IC		
R407, 410	3.3 Ohm	7.5 Ohm		VR302			4.99V
R408, 409	3.3 Ohm	7.5 Ohm	7.5 Ohm	VR303	6.2V	10V	10V
R411	0 Ohm	0 Ohm		VR304, 305	2.4V	3.6V	3.6V
R412	215K	215K	383K	VR335	6.2V	9.1V	9.1V



Table 6-2. A1 Board Component Locations

Ref.	X	Y	Ref.	X	Y	Ref.	X	Y	Ref.	X	Y	Ref.	X	Y
C300	8.125	3.25	C371	5.05	7.65	D323	1.025	4.9	R301	5.45	1.0	R366	1.3	3.925
C301	2.075	0.525	C372	1.875	7.9	D324	0.1	4.375	R302	6.275	0.1	R367	0.675	4.225
C302	7.5	1.925	C373	1.875	7.8	D325	0.15	7.125	R303	7.925	2.8	R368	1.125	5.0
C304	6.025	0.45	C374	0.3	8.325	D326	0.775	8.525	R304	5.85	2.1	R370	3.65	5.875
C307	5.45	0.45	C375	3.575	8.4	D327	1.0	8.025	R305	4.85	2.075	R371	2.075	5.8
C308	4.05	3.45	C376	1.2	9.875	D328	1.0	7.825	R306	5.3	1.975	R372	2.375	6.25
C309	8.025	2.8	C377	0.525	9.85	D329	0.425	8.425	R307	0.7	2.7	R373	3.175	9.275
C311	4.775	0.975	C378	1.775	10.42	D330	4.2	8.7	R308	1.15	2.8	R374	0.1	5.325
C312	4.875	1.425	C379	0.525	10.17	D331	5.15	0.8	R309	1.6	3.0	R375	0.675	4.125
C314	3.5	4.925	C380	4.675	6.975	D332	4.575	0.8	R310	1.7	3.5	R376	1.975	5.8
C315	3.825	4.7	C381	0.925	10.4	D333	5.775	0.8	R311	3.45	2.3	R377	0.55	4.475
C316	3.625	3.175	C382	3.0	10.45	D334	6.25	0.8	R312	1.4	1.75	R378	8.025	8.55
C317	1.15	2.5	C383	3.8	10.25	D336	4.65	6.4	R313	4.025	4.25	R379	0.1	4.125
C318	0.95	1.35	C384	0.3	9.35	D337	4.825	6.25	R314	0.6	3.1	R380	1.75	6.25
C319	3.525	1.475	C386	2.45	6.875	D400	3.375	7.7	R315	3.05	2.0	R381	0.55	5.625
C320	4.8	2.25	C403	1.775	8.475	D470	3.3	6.525	R316	4.825	7.025	R382	1.75	5.875
C321	3.975	1.925	C405	0.525	9.975	D471	3.65	6.175	R317	2.85	2.0	R383	1.125	5.425
C322	5.4	2.2	C411	2.825	8.3	D499	3.65	6.825	R318	2.95	2.0	R384	6.8	5.45
C323	5.4	2.0	C420	3.475	4.825	F300	1.875	0.075	R319	2.25	3.5	R385	2.275	6.25
C324	2.45	1.5	C421	3.3	4.825	F301	1.975	0.075	R320	2.15	3.4	R386	7.05	5.45
C326	0.175	2.05	C422	2.175	2.25	F302	4.725	0.425	R321	2.15	2.9	R387	5.7	5.1
C327	1.15	2.0	C423	1.7	3.2	F303	4.825	0.425	R322	1.7	3.6	R388	1.75	4.225
C328	0.475	2.7	C424	1.775	2.75	F304	0.275	2.05	R323	1.6	2.2	R389	5.95	5.1
C329	0.35	2.425	C425	0.525	6.7	F400	7.95	7.375	R324	4.75	4.85	R390	1.875	7.6
C330	1.25	2.9	C426	4.6	10.57	F401	8.05	5.425	R325	3.35	3.225	R391	1.875	7.3
C331	2.3	2.425	C427	2.1	10.47	F402	5.6	7.1	R326	4.65	5.3	R392	0.5	2.1
C332	1.925	2.7	C428	6.25	0.525	F403	5.55	4.8	R327	0.6	3.0	R393	2.225	2.0
C333	1.7	3.3	C429	5.375	0.425	F404	7.75	8.85	R328	3.475	5.025	R394	2.05	2.0
C334	1.125	4.625	C430	8.225	3.35	F405	7.95	6.275	R329	2.25	3.2	R395	2.425	7.4
C335	1.15	7.225	C431	1.75	10.47	F406	5.725	8.85	R330	4.15	3.175	R396	2.325	7.7
C336	1.05	7.65	C432	4.6	10.45	F407	5.65	5.925	R331	1.6	3.1	R397	8.275	8.55
C337	0.1	5.525	C480	3.75	6.2	F500	4.871	3.147	R332	2.25	3.0	R398	4.95	8.875
C338	0.7	7.35	C481	3.75	6.3	J303	0.15	2.75	R333	2.25	3.3	R399	0.875	8.225
C339	1.15	7.45	C482	3.2	3.75	J304	5.8	0.2	R334	4.125	4.25	R400	1.45	8.425
C340	1.5	2.35	C496	2.5	1.85	J305	1.575	0.15	R335	0.6	2.9	R401	1.45	8.225
C341	2.7	4.025	C497	3.05	1.825	J307	0.147	5.878	R336	1.6	3.2	R402	1.4	7.925
C342	1.05	5.875	C498	1.8	3.7	J309	2.075	10.63	R337	3.925	4.25	R403	2.6	8.3
C343	1.75	4.025	C499	2.875	7.95	J314	1.375	10.17	R338	1.7	2.8	R404	2.7	3.825
C344	3.75	6.4	C500	5.725	2.725	J320	2.25	9.55	R339	2.7	2.525	R405	0.425	8.325
C345	0.95	4.75	C501	6.35	3.1	J414	4.7	2.225	R340	2.675	2.1	R406	1.45	8.625
C346	3.65	6.075	C502	5.1	3.1	J508	6.35	3.45	R341	2.7	3.1	R407	5.95	6.9
C347	0.6	3.325	Cr342	3.9	8.9	L300	3.625	4.85	R342	1.7	3.0	R408	5.7	6.9
C348	1.95	5.15	D300	1.875	1.025	L301	3.5	5.2	R343	1.7	3.1	R409	7.05	7.325
C349	2.175	5.8	D301	1.975	1.025	P300	0.125	3.55	R344	1.75	4.125	R410	6.8	7.325
C350	0.1	5.425	D302	1.65	0.325	Q300	3.85	2.55	R345	0.6	3.2	R411	7.75	10.17
C351	2.4	5.65	D303	1.75	0.325	Q301	2.725	2.75	R346	2.25	3.4	R412	1.45	9.025
C352	1.95	5.65	D304	4.7	1.95	Q302	1.5	2.6	R347	0.675	5.2	R413	2.25	3.925
C353	1.875	6.25	D305	0.2	0.6	Q303	3.575	3.35	R348	2.05	2.1	R414	1.45	8.925
C354	2.375	6.35	D306	0.325	0.6	Q304	4.375	3.35	R349	2.4	9.7	R415	0.175	8.325
C355	0.55	4.575	D307	2.675	1.4	Q305	1.55	3.6	R350	1.15	7.0	R416	4.275	6.75
C356	0.3	4.25	D308	6.25	1.0	Q306	1.4	2.275	R351	1.65	8.3	R417	1.45	8.525
C357	1.925	7.05	D309	4.575	1.0	Q307	4.925	5.8	R352	1.675	2.6	R418	1.275	9.125
C358	2.25	6.775	D310	5.15	1.0	Q308	7.768	5.007	R353	0.1	4.775	R419	0.425	8.725
C359	0.775	8.125	D311	5.775	1.0	Q309	4.972	5.433	R354	1.15	7.1	R420	1.45	8.325
C360	1.35	8.125	D312	4.275	2.55	Q310	7.768	6.109	R355	2.25	3.6	R421	5.95	7.2
C361	0.65	9.95	D313	0.225	1.5	Q311	4.972	6.535	R356	0.7	7.55	R422	0.425	8.625
C362	0.775	8.025	D314	0.35	1.5	Q312	7.768	7.211	R357	0.55	4.675	R423	0.1	8.425
C363	1.975	7.5	D315	1.1	2.6	Q313	3.9	7.4	R358	0.675	4.325	R425	1.875	4.4
C364	1.875	6.9	D316	7.975	4.3	Q314	3.35	7.025	R359	3.625	4.25	R427	2.7	3.725
C365	0.7	8.9	D317	3.725	4.25	Q315	4.972	8.248	R360	1.125	4.425	R428	8.025	9.425
C366	2.275	8.0	D318	4.25	4.25	Q316	0.65	7.85	R361	1.25	3.725	R429	0.2	9.45
C367	0.175	9.0	D319	3.625	4.5	Q317	7.768	8.313	R362	1.125	4.525	R430	1.975	4.4
C368	0.2	8.425	D320	4.125	4.5	Q318	4.8	7.625	R363	1.275	4.425	R431	4.95	7.1
C369	1.35	7.65	D321	1.75	2.5	Q319	4.972	10.05	R364	1.125	5.1	R432	1.65	9.15
C370	0.075	9.55	D322	1.65	4.325	R300	8.225	0.725	R365	1.75	3.825	R433	1.925	8.75

## 6 - Diagrams

**Table 6-2 continued**

Ref.	X	Y	Ref.	X	Y
R434	2.5	9.825	R500	2.175	4.325
R435	2.4	9.825	R505	0.525	6.8
R436	7.05	7.75	R510	6.2	5.1
R437	6.8	7.75	R511	6.2	7.2
R438	4.675	6.875	R512	6.55	5.45
R439	1.925	8.65	R513	6.55	7.75
R440	5.7	7.2	R514	6.2	6.9
R441	5.05	7.125	R515	6.2	9.9
R442	0.35	9.65	R516	6.55	7.325
R443	0.2	9.55	R517	6.55	9.75
R444	4.375	7.9	R520	4.15	9.75
R445	3.425	9.275	R521	2.5	6.05
R446	0.9	9.65	R522	4.25	1.75
R447	2.4	8.45	Rt301	7.4	10.43
R448	1.95	9.675	S300	4.291	10.63
R449	1.95	9.775	T300	4.35	9.925
R450	1.925	8.85	Tp318	4.825	6.05
R451	0.825	9.25	Tp319	4.975	7.63
R452	1.95	9.25	Tp320	4.975	9.475
R453	2.375	8.55	Tp321	4.825	5.15
R454	1.35	9.75	Tp323	3.825	8.825
R455	0.075	9.75	U300	3.85	1.725
R456	1.225	10.02	U301	1.275	1.625
R457	1.125	10.02	U302	3.85	2.15
R458	2.2	9.825	U303	6.275	2.3
R459	2.1	9.825	U304	2.775	1.725
R460	0.6	2.55	U305	1.05	2.4
R461	4.675	7.375	U306	0.575	7.05
R462	4.675	7.275	U308	4.6	5.675
R463	8.275	9.425	U309	2.375	5.55
R464	4.225	7.075	U310	0.475	4.9
R465	4.675	7.175	U311	2.25	6.675
R466	3.6	9.8	U313	2.15	3.825
R467	5.7	9.9	U314	2.175	8.025
R468	5.95	9.9	U315	0.575	8.875
R469	6.8	9.75	U400	0.825	5.6
R470	7.05	9.75	U498	3.925	3.45
R471	4.925	10.82	U499	3.925	3.15
R472	4.725	6.6	Vr300	4.7	1.85
R473	2.7	5.4	Vr301	4.7	2.05
R474	7.85	9.125	Vr302	4.0	5.025
R476	0.525	6.6	Vr303	1.45	8.825
R477	3.75	5.7	Vr304	0.45	4.025
R478	3.2	5.775	Vr305	1.45	8.725
R479	3.2	5.675	Vr335	1.175	4.025
R480	3.75	6.1	W300	3.625	9.45
R481	3.75	6.0	W301	4.65	7.475
R482	4.2	5.8			
R483	4.2	5.9			
R484	4.025	3.6			
R485	3.925	3.675			
R486	3.725	4.125			
R487	3.825	3.675			
R488	0.525	6.9			
R489	0.525	6.8			
R490	1.35	6.775			
R493	1.2	6.675			
R494	3.1	8.85			
R495	3.2	8.85			
R496	3.65	5.975			
R497	4.275	6.5			
R498	3.75	6.55			
R499	3.2	6.775			

**Figure 6-1. A1 Board Component Locations**

**Figure 6-2. A4 and A6 Board Component Locations**

**Figure 6-3. A1 Board schematic (sheet 1)**

6 - Diagrams

**Figure 6-3. A1 Board schematic (sheet 2)**

**Figure 6-3. A1 Board schematic (sheet 3)**

## 6 - Diagrams

**Figure 6-4. A6 Relay Option Board schematic**



# Index

—+—

+OUT, 47  
+sense, 47

—A—

A1 board removal, 45  
A1 Main board, 50  
A2 board removal, 44  
A2 Interface Board, 48  
A2S201, 50  
A3 board removal, 45  
A3 Front Panel, 48  
ADC, 48

—B—

bias voltages, 38, 39

—C—

cal denied, 41  
calibration, 41  
calibration - post repair, 41  
CC, 38  
CC line regulation, 17  
CC load effect, 18  
CC load regulation, 17  
CC loop, 52  
CC noise, 19  
CC- operation, 17  
CC source effect, 18  
CC\_Detect\*, 48, 52  
CC\_Prog, 50, 52  
clear password, 41  
component locations  
    A1, 71, 72, 73, 74  
    A4, 76  
constant current tests, 16  
constant voltage tests, 14  
Control, 50, 52  
copyrights, 5  
cover removal, 44  
current monitoring resistor, 13  
current sink, 17  
CV, 38  
CV load effect, 14  
CV loop, 52  
CV Noise, 15  
CV source effect, 15  
CV/CC control, 50, 52

CV\_Detect\*, 48, 52  
CV\_Prog, 50, 52

—D—

DAC, 48  
disable protection, 40  
disassembly - tools, 43  
disassembly procedure, 43  
downprogramming, 50, 52  
DP\_Control, 50

—E—

EEPROM, 50  
electronic load, 13  
electrostatic discharge, 10  
error codes, 37

—F—

F309, 50  
fan speed, 40  
Fan\_Prog, 50, 52  
firmware revisions, 10, 42  
FLT, 47  
front panel removal, 44, 45  
Fuse, 50

—G—

GPIB, 47

—H—

hazardous voltages, 9  
history, 5  
HS\_Therm, 50

—I—

identification, 5  
IDN? query, 42  
Imon\_H, 50  
Imon\_H, 52  
Imon\_L, 50  
Imon\_P, 50  
INH, 47  
inhibit calibration, 41  
initialization, 42  
interface signals, 47

## Index

### —J—

J307 voltages, 39

### —L—

line voltage wiring, 46

### —M—

manual revisions, 10

### —N—

notice, 5

### —O—

-OUT, 47

out of range, 41

OV\_Detect\*, 48, 52

OV\_Prog, 50

OV\_SCR\*, 48, 52

### —P—

PARD, 15, 19

password, 41

performance test form, 19

performance tests, 13

PM\_Inhibit, 52

power-on self-test, 37

primary interface, 48

printing, 5

programming, 13

protection, 40

### —R—

readback accuracy, 14

reference voltages, 38, 39

replaceable parts - binding posts, 57

replaceable parts - chassis, 55

revisions, 10

RmHi, 52

RmLo, 52

ROM upgrade, 42

RPG, 48

RS-232, 47

### —S—

safety considerations, 9

safety summary, 3

schematic

A1, 77, 78, 79

A4, 76

schematic notes, 71

SCR, 52

secondary interface, 48

self-test, 37

-sense, 47

sense switch, 52

serial number, 5

series regulator, 50

shunt clamp, 52

status annunciators, 38

### —T—

Temp\_Amb, 50

test equipment, 11

test setup, 12

trademarks, 5

transformer removal, 45

transient recovery, 16

troubleshooting - bias and reference supplies, 38, 39

troubleshooting - equipment, 24

troubleshooting - flowcharts, 24

troubleshooting - introduction, 23

troubleshooting - overall, 24

troubleshooting - status annunciators, 38

### —U—

UNR, 38

### —V—

verification tests, 13

VMon, 50, 52

voltage programming, 14

### —W—

warranty, 2